

WHEEL LOADER
HL960A

HL960AHD / HL960AHDXT / HL960AXT





READY TO CHANGE YOUR WORLD

The HL960A Wheel Loader is part of Hyundai's brand new A-Series: a fresh generation of construction equipment that complies with the European stage V emission levels. But it does much more than that! While fulfilling regulatory demands, Hyundai aimed for a ground-breaking level of customer satisfaction with maximum performance and productivity, better safety, more convenience and improved uptime management.

Featuring impressive power matched with carefully selected technologies that help you to work more efficiently and economically, this 19-tonne loader opens up a world of new possibilities. It's time to experience the Hyundai Effect!

ENTER A WORLD WHERE ANYTHING IS POSSIBLE



Productivity

- Load sensing hydraulic system
- Electro-hydraulic control
- Accurate weighing control system
- Eco pedal (option)
- 5-speed transmission with lock-up clutch
- Intelligent clutch cut-off (ICCO)

Durability/Safety

- AAVM camera system (option)
- LED lights (option)
- Premium quality axles
- Sinter brake discs
- Axle cooling (option)
- Thermostat-based transmission cooling
- Completely sealed engine room
- High grade hoses
- Radar rear detection (option)

Comfort

- Spacious cabin
- 7" touchscreen monitor
- Ride control system
- Air suspension seat with heater
- Fully adjustable armrests
- Joystick steering (option)
- Fingertip control (option)

Serviceability

- Fully openable engine hood
- Extended service intervals
- Hi-MATE telematic system
- Vertically stacked coolers
- Reversible fan

PROTECTION FOR WORKERS AND EQUIPMENT

Details can make a huge difference when it comes to safety, especially when you're working in rough conditions. It's not just a matter of complying with rules. The HL960A's safety features are designed and tested to meet your needs in the real world, even offering an extra pair of eyes with the optional Advanced Around View Monitoring (AAVM) and radar systems. Operator confidence is improved by technologies that provide a feeling of stability and smooth performance in high-load work. By helping to ensure a calm, accident-free worksite, this wheel loader adds to the productivity and peace of mind that are all part of the Hyundai Effect.

A **ride control system** with a piston accumulator reduces pitching of the wheel loader body and bucket for more stable and comfortable operation. It also minimises spillover, adding to convenience and productivity.

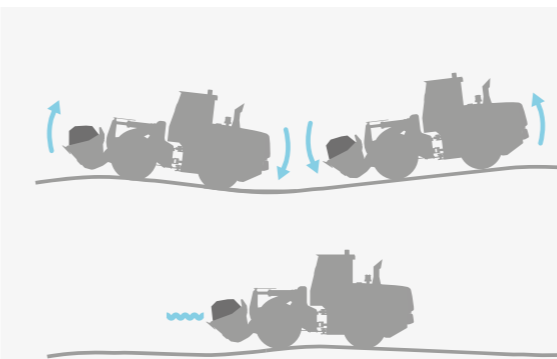

A **hydraulic locking differential** prevents tyre slip for better productivity and fuel economy.

The optional **Advanced Around View Monitoring (AAVM)** system gives you a 360° overview of your immediate working environment. It also includes Intelligent Moving Object Detection (IMOD) technology that senses and warns you when people or objects come within five metres of the machine.

The newly designed **engine hood** drastically improves visibility for the operator.



Operators are reminded to fasten their **safety belt** by an **audible and visible alarm**.

The optional **radar system** detects obstacles behind the machine day and night, with no blind spots. The distance between the obstacle and the loader is displayed on the monitor.

"It looks tough but its performance is incredibly smooth and predictable. It gives me extra confidence and a feeling of safety wherever I'm working."

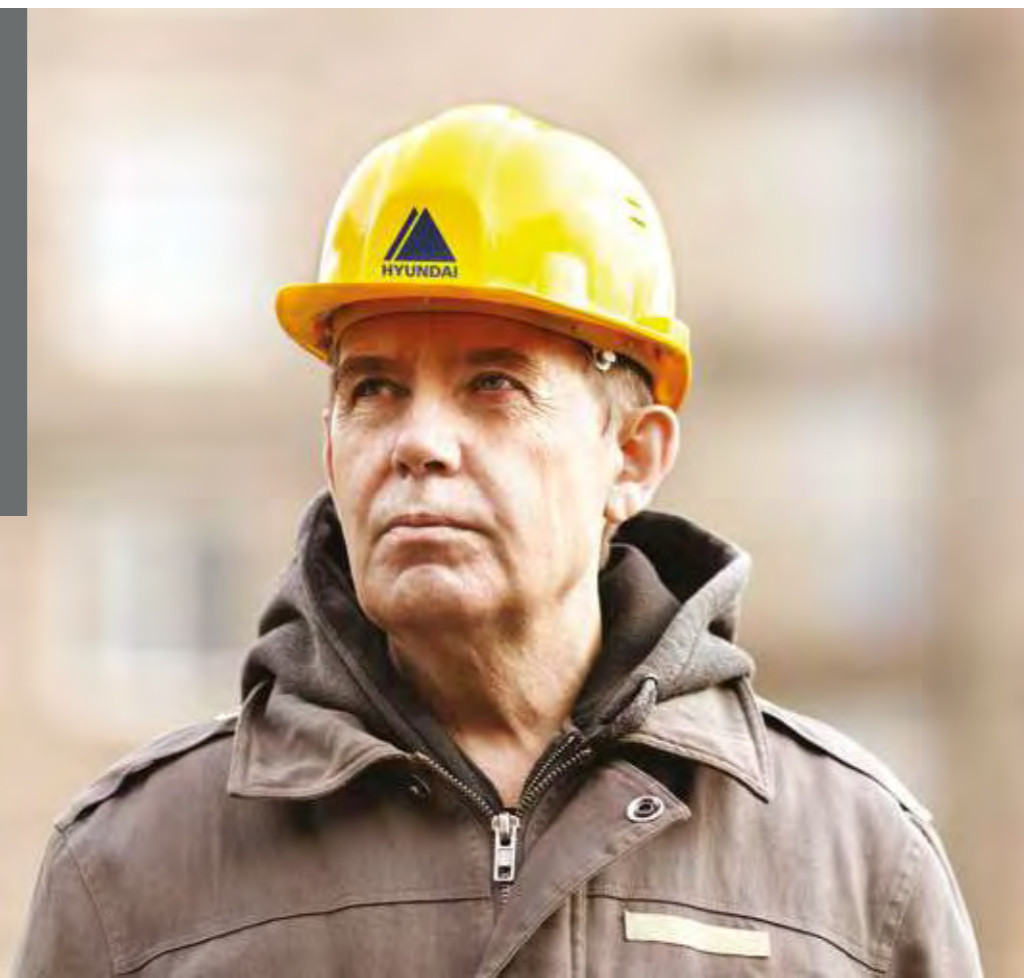

HYUNDAI





“Everything I need is right here at my fingertips and the controls are so intuitive that it feels almost as if I’m part of the machine.”



The HL960A has a **large comfortable seat** with heating as standard. The seat and armrest are fully adjustable and, for added comfort, an air suspension version is available as an option. Thanks to the **electro-hydraulic implement control lever**, less force is needed to operate attachments, helping you to work longer and more productively.

The cabin door can optionally be **opened remotely** from the ground level for added safety and convenience.

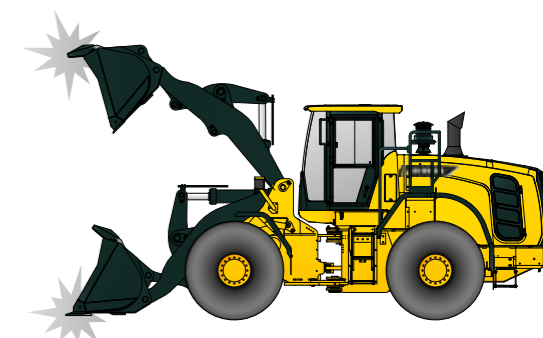

The **soft end stop** function reduces the hydraulic speed of the cylinder as it reaches the end of its stroke. This lessens the shock load of the stroke for increased operating comfort and better material retention.

A CABIN DESIGNED AROUND YOU

The HL960A cabin was designed to be a productive, stress-free working environment that fits every operator perfectly. Pleasant and spacious, it features state-of-the-art noise and vibration reduction technology, achieving a sound level of only 68 dB, one of the lowest in this machine category. The high-quality, adjustable seat provides comfortable reach to all controls. A range of technologies enable easier machine monitoring, while the audio system includes radio, USB and AUX input to keep you entertained during your working day.



The **Eco Report** feature makes it easy for operators to develop efficient working habits by displaying real-time information about machine performance.

The **instrument panel** is optimised to provide quick, easy access to machine status information as you work. It features a seven-inch **touchscreen monitor** for excellent legibility.

All the indicators displaying **machine status** are centralised in one cluster to enable easy, efficient control.



TAILORED TECHNOLOGIES FOR BETTER PRODUCTIVITY

The HL960A's reliable Cummins B6.7 Stage V engine delivers immense power to handle heavy-duty work in extreme conditions. It is complemented by a range of technologies that enhance fuel efficiency while keeping harmful emissions to a minimum.

Precise operating systems help you to get the most out of this mighty machine, including optimised power

matching for the ultimate balance of torque and RPM. When operated in Power Smart mode, the engine delivers fuel savings of 3-5% as well as smooth performance in high-load work such as digging. Hyundai's proprietary weighing system technology is integrated as standard. Additional control, monitoring and maintenance features help you to optimise performance and productivity every single day, on any worksite.



Like all A-Series machines, the HL 960A features our **all-in-one exhaust aftertreatment system** which cuts emissions and operating costs while enhancing reliability and simplifying maintenance.



The highly accurate **automatic/manual cumulative weighing system** helps you to manage production more efficiently in any environment. For maximum precision, weighing error icons and a two-colour weight value indicator are displayed on the monitor.



The **electro-hydraulic control system** improves handling precision and comfort, giving you effortless control in any working conditions.



The **engine shuts down automatically when the machine is at rest** to cut fuel consumption and prevent unnecessary emissions. Different operating modes and idling times can be selected according to the work environment, further enhancing efficiency.



"It's an incredible feeling to be in control of all that power. High-load work, rough terrain... I really feel as if I can tackle anything!"

The HL960A is equipped with a **five-speed transmission and a lockup clutch**, allowing you to work more efficiently while keeping fuel consumption and emissions low.



MORE UPTIME FOR A SUSTAINABLE RETURN ON YOUR INVESTMENT

To protect your business, you need to know that the investment you make today will sustain your profits over the long term. That's why we prioritised reliability throughout the development of the HL960A, from design and manufacturing to quality control. The frame and bucket have been further enhanced for maximum strength, while tailored

protective guards are available as options to safeguard vital components from debris. The driveshaft and all operating systems have been optimised for endurance and tested rigorously on a range of work sites. The result is a tough, durable workhorse that minimises downtime for repairs and maintenance and helps you to protect your profits.

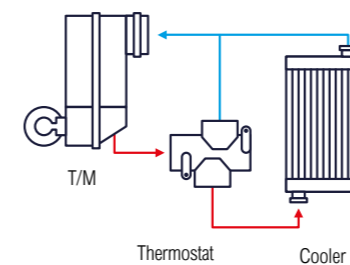

The HL960A is equipped with a **thermostat for transmission cooling**. This feature helps to warm up the fluid quickly and keeps it at the optimal working temperature, protecting components and increasing efficiency.

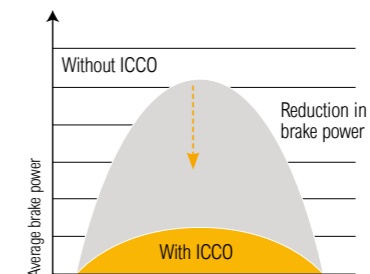

The **Intelligent Clutch Cut-Off (ICCO)** function minimises loss of power in the torque converter and prevents excessive power use during braking. This reduces heat generation and wear on the brake disc.

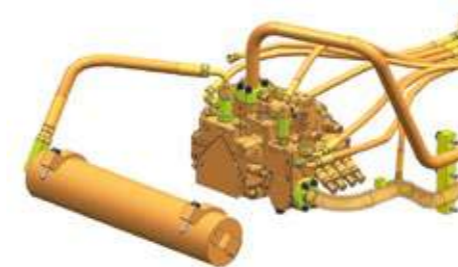

The hydraulic system has been simplified with a **unified control valve system**. This removes the need for hydraulic hoses connected to each valve, decreasing the number of possible leak points.

High-grade hoses with outstanding resistance to heat and pressure provide maximum durability, even in rough working conditions.

The HL960A features **premium quality axles with enhanced load capacity** for better reliability and durability. A separate **axle oil cooling system** is available as an option to prevent overheating during high-load work or tasks requiring frequent braking.

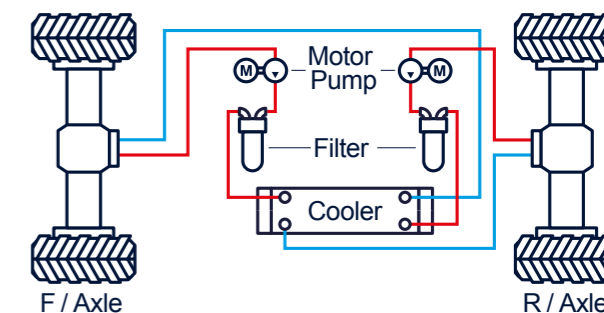

HL960AHD – OPTIMISED FOR CONTINUOUS HEAVY-DUTY WORK

The HL960A also comes in a heavy-duty version – the HL960AHD – to add even more value for our customers who are engaged in high-load work in tough conditions. This rugged workhorse is enhanced with heavy-duty components and protection wherever possible to ensure the ultimate reliability and durability.



◀ A **rear grill guard** protects the engine hood, rear view camera, work lights and radiators from contact with any obstacles. The design does not impede the operator's view. The steel guard is hinged and opens to allow easy access to the radiator for cleaning or daily maintenance.



▲ A **steel grill housing** protects the front and rear working lights from material spill from the bucket.

▲ A **steel plate** covers the bucket cylinder rod to protect it from falling debris or material spill from the bucket. The plate is mounted to the cylinder and independent from cylinder movements. **Strong steel plates** are also mounted on both sides of the front frame. These **prevent damage to the hydraulic hoses** caused by sharp materials when working in recycling or demolition applications.



▼ **Under-guards** are bolted to the frame to protect the main components from contact with objects and prevent material from entering the engine, transmission or MCV environment.



▲ The **axles** of the HL960AHD are designed for uncompromising reliability during continuous heavy-duty work. Despite its great stability and power transmission capacity, the wheel loader axle has a compact design and low weight. The use of wet multi-disc brakes reduces braking losses and thus improves efficiency.

Advantages

- Long service life, robust design, and maximum operating smoothness
- Ensures high efficiency by preventing braking losses and optimising oil flow
- Easy servicing and low-wear brakes
- Excellent ground clearance due to compact design

▼ The HL960AHD can be delivered with optional Trelleborg Brawler **Soft ride solid tyres** ex factory.



▼ **Cabin guards** protect the front and rear windows from damage when working in tough conditions, while also allowing an unobstructed view of the work environment. The front guard is hinged and opens easily for cleaning of the windshield.

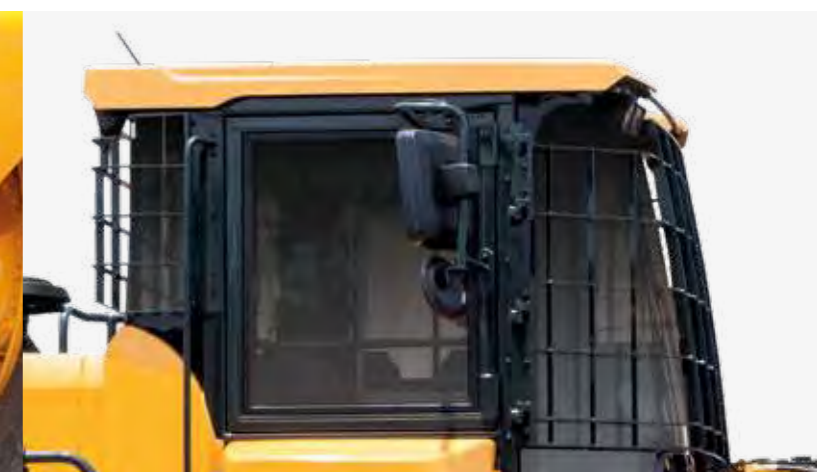

EASY SERVICING FOR TROUBLE-FREE OWNERSHIP

The peace of mind that comes with quick, low-effort servicing is also part of the Hyundai Effect. The HL960A is designed to make maintenance as convenient as possible. The engine hood opens wide to provide easy access for cleaning and routine tasks. All components and materials have been optimised to ensure a long, trouble-free life.

Hyundai's Hi-MATE remote management system uses GPS satellite technology to provide the highest level of service and support. The HL960A also features our new Engine Connected Diagnostics (ECD) system which immediately reports any engine failure to both Hi-MATE and the engine manufacturer to ensure the fastest, easiest resolution.

HiMATE

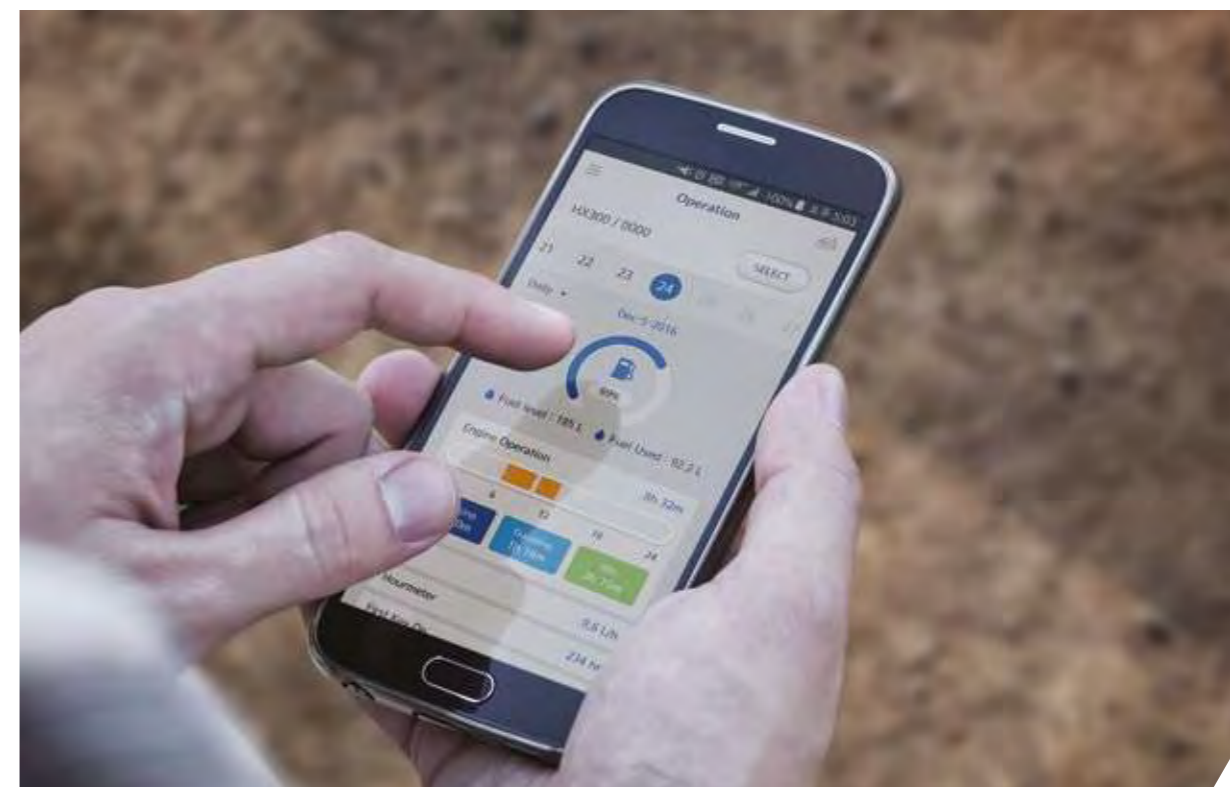

For maximum convenience and security, the HL960A features Hyundai's exclusive Hi-MATE remote management system. This allows you to monitor your machines from any location via a dedicated website or mobile app, with access to diagnostics and working parameters like total engine hours, actual working hours and fuel consumption. The system makes it easy to evaluate machine productivity and plan servicing and maintenance tasks, as well as any required cost saving measures. It also offers geofencing to protect your machines against theft and unauthorised usage.



With the optional **auto greasing system**, grease is applied to lubrication points automatically when needed. The correct dosing is ensured and lubricant is applied uniformly, reducing grease consumption and eliminating waste.



The **tilt-back engine hood** is fully retractable and can be opened electrically for easy access to the sealed engine room and cooling room. The engine room is designed to prevent the possibility of fire caused by the inflow of foreign materials.



The **air conditioning filter** is easy to replace and is made from a specially selected material for superior performance.

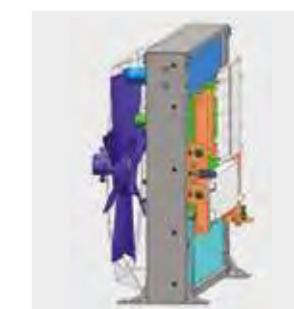

The HL960A has a dependable **wide-core and fin air cooler** that prevents performance degradation caused by contamination. It is also equipped with a **reversible fan** to eliminate dust and debris.

FOCUSED TECHNOLOGIES FOR THE RESULTS YOU WANT

Hyundai's A-Series wheel loaders are designed to create better conditions for operators and deliver the ultimate ownership experience. Every detail is carefully fine-tuned to match your needs in the field, including better safety and comfort, higher productivity, maximum uptime and easy servicing. It's all part of the Hyundai Effect.

See more at hyundai-ce.eu



SPECIFICATIONS

ENGINE	
Maker / Model	CUMMINS / B6.7 / EU Stage V
Type	Turbocharged, charge air cooled, diesel engine
Aftertreatment System	DOC, DPF, SCR, VGT
Gross power (SAE J1995)	225 HP (166 kW) at 2,200 rpm
Net power (SAE J1349)	222 HP (166 kW) at 2,200 rpm
Max. Power	251 HP (188 kW) at 1,900 rpm
Peak gross Torque (SAE J1995)	1,186 N m (875 lb.ft) at 1,300 rpm
Displacement	6.7 l (408 cu in)

· The indicated net power is available for the flywheel when the engine is equipped with a fan, alternator, air cleaner, and after-treatment device.
 · The indicated gross power is obtained with the fan at maximum speed.

TRANSMISSION					
Travel speed		4 speed T/M		5 speed T/M with lock up clutch	
		km/h	mph	km/h	mph
Forward	1st	6.3	3.9	6.7	4.1
	2nd	12.1	7.5	11.9	7.3
	3rd	24.5	15.2	18.2	11.2
	4th	39.6	24.6	28.4	17.5
	5th	-	-	40	24.8
Reverse	1st	6.8	4.2	7.1	4.4
	2nd	12.8	7.9	12.5	7.7
	3rd	25.7	15.9	29.9	18.5

· This is the maximum travel speed of a standard machine with unfilled bucket.

AXLES	
Drive System	Four-wheel drive system
Mount	Rigid front axle and oscillating rear axle
Rear Axle Oscillation	Oscillation ±12° of center pin-loaded
Hub Reduction	Planetary reduction at wheel end
Differential	Conventional
Reduction Ratio	24.667

TYRES	
Type	Tubeless, loader design tyres
Standard	23.5 R25, L3
Options include	23.5 R25, XHA2

BRAKES	
Service Brakes	Hydraulically actuated, wet disc brakes actuate all 4 wheels, independent axle-by-axle system. Self adjusting & wheel speed brake.
Parking Brake	Spring-applied, hydraulically released brake
Emergency Brake	When brake oil pressure drops, indicator light alerts operator and parking brake automatically applies.

HYDRAULIC SYSTEM		
Implement Pump Type	Load sensing hydraulic system	
Implement System		
Maximum Pump Output	239 ℓ /min (63.1 gal/min) at 2,130 rpm	
Maximum Operating Pressure	280 bar (4,061 psi)	
Hydraulic cycle time with rated payload	Raise from Carry Position: 5.9 Sec.	
	Dump, at maximum raise: 1.5 Sec.	
	Lower, empty, float down: 3.5 Sec.	
	Total: 10.9 Sec.	
Cylinder	Type: double acting	
	No. of cylinders-bore x stroke:	
	Lift	mm 2-140 x 765 in 2-5.5 x 30.1
	HL960A Tilt	mm 1-160 x 530 in 1-6.3 x 20.9
	HL960A XT Tilt	mm 1-160 x 530 in 1-6.3 x 20.9

STEERING SYSTEM	
Type	Load sensing hydrostatic articulated steering
Pump	Variable displacement piston pump, 148.5 l/min (39.2 gal/min)
System Pressure	210 bar (3,046 psi)
Cylinder	Double acting 2-80 mm (3.15") x 424 mm (16.7")
Steering Angle	40° to both right and left angle, respectively

* Hyundai Bio Hydraulic Oil (HBHO) available.

SERVICE REFILL CAPACITIES		
UNIT	l	US gal
Fuel tank	260.0	68.6
DEF tank	37.1	9.8
Cooling system	42.0	11.1
Crankcase	18.0	4.7
Transmission	33.0	8.7
Front axle	35.0	9.2
Rear axle	35.0	9.2
Hydraulic tank	110.0	29.0
Hydraulic system (including tank)	200.0	52.8

CABIN	
ROPS / FOPS	meet ISO 3471 and ISO 3449 level II standards

SOUND	
Guaranteed noise level presented below can be differed depending on a range of factors such as operating condition, speed of a cooling fan, types of engine and so forth. Hearing protection shall be necessary if an operator is working in the improperly maintained cabin or exposed to a noisy environment by leaving doors and/or windows open.	
With Cooling Fan Speed at Maximum Value:	
Operator Sound Pressure Level (ISO 6396:2008)	70 dB à 68 dB
Exterior Sound Power Level (ISO 6395:2008)	105 dB(A)

* Distance of 15 m (49.2 ft), moving forward in second gear ratio.

AIR CONDITIONING SYSTEM	
The air conditioning system contains fluorinated greenhouse gas refrigerant R134a (Global Warming Potential = 1,430). The system contains 0.75 kg of refrigerant representing a CO ₂ equivalent of 1.0725 metric tonnes.	

DIMENSIONS

HL960A DIMENSIONS

All dimensions are approximate.

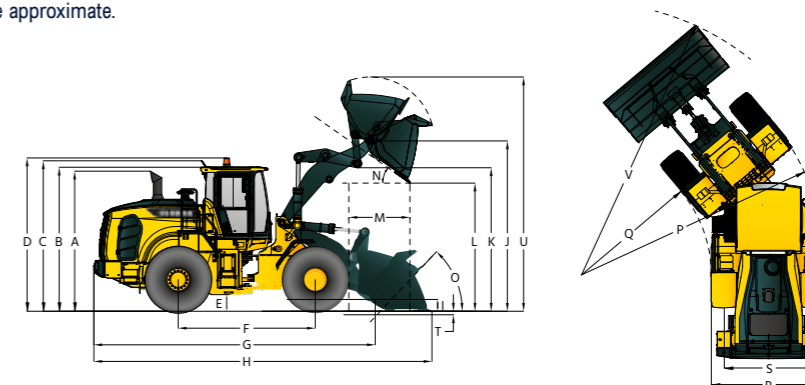

Description	HL960A		HL960AXT	
	mm	ft in	mm	ft in
A. Height to Top of Exhaust Pipe	3,340	10' 11"	3,340	10' 11"
B. Height to Top of Cabin	3,450	11' 3"	3,450	11' 3"
C. Height to Top of Product Link Antenna	3,505	11' 6"	3,505	11' 6"
D. Height to Top of Warning Beacon	3,580	11' 9"	3,580	11' 9"
E. Ground Clearance	410	1' 4"	410	1' 4"
F. Wheelbase	3,300	10' 10"	3,300	10' 10"
G. Overall Length (without bucket)	6,870	22' 6"	7,425	24' 4"
H. Shipping Length (with bucket level on ground)	8,140	26' 8"	8,695	28' 6"
I. Hinge Pin Height at Carry Position	465	1' 6"	600	2'
J. Hinge Pin Height at Maximum Lift	4,105	13' 6"	4,535	14' 11"
K. Lift Arm Clearance at Maximum Lift	3,455	11' 4"	3,885	12' 9"
L. Dump Clearance at Maximum Lift and 45° Discharge	2,935	9' 8"	3,365	11'
M. Reach at Maximum Lift and 45° Discharge	1,285	4' 2"	1,380	4' 6"
N. Dump Angle at Maximum Lift and Dump (on stops)	50		50	
O. Roll Back Angle	Ground	42	42	
	Carry	47	48	
P. Clearance circle (diameter) to outside of tyres	12,060	39' 6"	12,060	39' 6"
Q. Clearance Circle (diameter) to Inside of tyres	6,430	21' 1"	6,430	21' 1"
R. Width over tyres (unloaded)	2,770	9' 1"	2,770	9' 1"
S. Tread Width	2,160	7' 1"	2,160	7' 1"

OPERATING SPECIFICATIONS WITH BUCKETS

Linkage	bucket type	Standard Linkage					High Lift Linkage Change
		general purpose - pin on				General purpose - hook on	
Edge type		Bolt-on cutting edges	1 Piece tooth	2 Piece tooth	2 Piece tooth & segment	Bolt-on cutting edges	
Capacity - rated	m³ (yd³)	3.3 (4.3)	3.2 (4.2)	3.2 (4.2)	3.3 (4.3)	3.3 (4.3)	-
Capacity - rated at 110% fill factor	m³ (yd³)	3.6 (4.7)	3.5 (4.6)	3.5 (4.6)	3.6 (4.7)	3.6 (4.7)	-
Width	mm (ft/in)	2,900 (9' 6")	2,950 (9' 8")	2,970 (9' 9")	2,970 (9' 9")	2,900 (9' 6")	-
Dump clearance at maximum lift and 45° discharge	mm (ft/in)	2,935 (9' 7")	2,810 (9' 3")	2,775 (9' 2")	2,775 (9' 2")	2,775 (9' 2")	+430 (+1' 5")
Reach at maximum lift & 45° discharge	mm (ft/in)	1,285 (4' 3")	1,370 (4' 6")	1,390 (4' 7")	1,390 (4' 7")	1,465 (4' 10")	+95 (+4")
Digging depth	mm (ft/in)	90 (3.5")	115 (4.5")	125 (4.9")	125 (4.9")	90 (3.5")	+55 (+2")
Shipping length (with bucket)	mm (ft/in)	8,140 (26' 8")	8,290 (27' 2")	8,330 (27' 4")	8,330 (27' 4")	8,395 (27' 7")	+555 (+1' 10")
Overall height with bucket at maximum lift	mm (ft/in)	5,640 (18' 6")	5,640 (18' 6")	5,640 (18' 6")	5,640 (18' 6")	5,820 (19' 1")	+430 (+1' 5")
Loader clearance circle with bucket at carry position (V)	mm (ft/in)	13,410 (44')	13,570 (44' 6")	13,620 (44' 8")	13,620 (44' 8")	13,570 (44' 6")	+450 (+1' 6")
Static tipping load, straight (No tyres deflection)	kg (lbs)	14,300 (31,525)	14,500 (31,965)	14,500 (31,965)	14,250 (31,415)	13,080 (28,835)	-1,350 (-2,975)
Static tipping load, articulated (No tyres deflection)	kg (lbs)	12,410 (27,360)	12,580 (27,735)	12,580 (27,735)	12,360 (27,250)	11,350 (25,020)	-1,300 (-2,865)
Breakout force	kg (lbs)	16,670 (36,750)	17,705 (39,030)	17,705 (39,030)	16,670 (36,750)	13,870 (30,580)	-240 (-530)
Operating weight*	kg (lbs)	19,200 (42,330)	19,125 (42,160)	19,125 (42,160)	19,250 (42,440)	19,590 (43,190)	+830 (+1,830)

* All height and tyre related dimensions are with standard 23.5 R25, L3 tyres.

DIMENSIONS

HL960AHD DIMENSIONS

All dimensions are approximate.

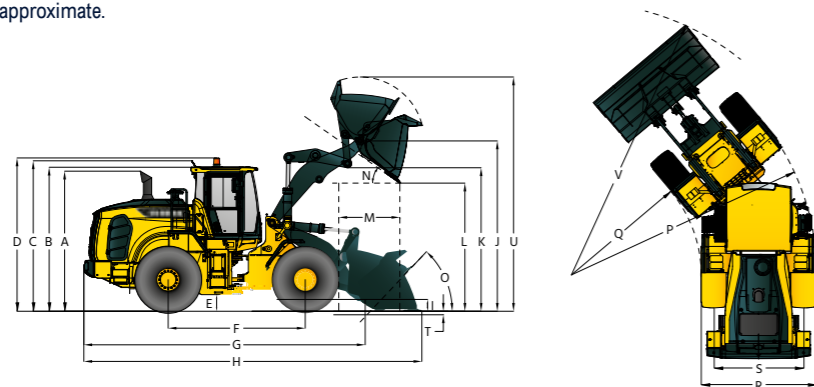

Description	HL960AHD		HL960AHDXT	
	mm	ft in	mm	ft in
A. Height to Top of Exhaust Pipe	3,340	10' 11"	3,340	10' 11"
B. Height to Top of Cabin	3,450	11' 3"	3,450	11' 3"
C. Height to Top of Product Link Antenna	3,505	11' 6"	3,505	11' 6"
D. Height to Top of Warning Beacon	3,580	11' 9"	3,580	11' 9"
E. Ground Clearance	410	1' 4"	410	1' 4"
F. Wheelbase	3,300	10' 10"	3,300	10' 10"
G. Overall Length (without bucket)	6,870	22' 6"	7,425	24' 4"
H. Shipping Length (with bucket level on ground)	8,140	26' 8"	8,695	28' 6"
I. Hinge Pin Height at Carry Position	465	1' 6"	600	2'
J. Hinge Pin Height at Maximum Lift	4,105	13' 6"	4,535	14' 11"
K. Lift Arm Clearance at Maximum Lift	3,455	11' 4"	3,885	12' 9"
L. Dump Clearance at Maximum Lift and 45° Discharge	2,935	9' 8"	3,365	11'
M. Reach at Maximum Lift and 45° Discharge	1,285	4' 2"	1,380	4' 6"
N. Dump Angle at Maximum Lift and Dump (on stops)	50		50	
O. Roll Back Angle	Ground	42	42	
	Carry	47	48	
P. Clearance circle (diameter) to outside of tyres	12,060	39' 6"	12,060	39' 6"
Q. Clearance circle (diameter) to inside of tyres	6,430	21' 1"	6,430	21' 1"
R. Width over tyres (unloaded)	2,770	9' 1"	2,770	9' 1"
S. Tread width	2,160	7' 1"	2,160	7' 1"

OPERATING SPECIFICATIONS WITH BUCKETS

Linkage	Standard Linkage					High Lift Linkage Change	
	bucket type	general purpose - pin on					General purpose - hook on
Edge type		Bolt-on cutting edges	1 Piece tooth	2 Piece tooth	2 Piece tooth & segment	Bolt-on cutting edges	
Capacity - rated	m³ (yd³)	3.3 (4.3)	3.2 (4.2)	3.2 (4.2)	3.3 (4.3)	3.3 (4.3)	-
Capacity - rated at 110% fill factor	m³ (yd³)	3.6 (4.7)	3.5 (4.6)	3.5 (4.6)	3.6 (4.7)	3.6 (4.7)	-
Width	mm (ft/in)	2,900 (9' 6")	2,950 (9' 8")	2,970 (9' 9")	2,970 (9' 9")	2,900 (9' 6")	-
Dump clearance at maximum lift and 45° discharge	mm (ft/in)	2,935 (9' 7")	2,810 (9' 3")	2,775 (9' 2")	2,775 (9' 2")	2,775 (9' 1")	+430 (+1' 5")
Reach at maximum lift & 45° discharge	mm (ft/in)	1,285 (4' 3")	1,370 (4' 6")	1,390 (4' 7")	1,390 (4' 7")	1,465 (4' 10")	+95 (+4")
Digging depth	mm (ft/in)	90 (3.5")	115 (4.5")	125 (4.9")	125 (4.9")	90 (3.5")	+55 (+2")
Shipping length (with bucket)	mm (ft/in)	8,140 (26' 8")	8,290 (27' 2")	8,330 (27' 4")	8,330 (27' 4")	8,395 (27' 7")	+555 (+1' 10")
Overall height with bucket at maximum lift	mm (ft/in)	5,640 (18' 6")	5,640 (18' 6")	5,640 (18' 6")	5,640 (18' 6")	5,820 (19' 1")	+430 (+1' 5")
Loader clearance circle with bucket at carry position (V)	mm (ft/in)	13,410 (44')	13,570 (44' 6")	13,620 (44' 8")	13,620 (44' 8")	13,570 (44' 6")	+450 (+1' 6")
Static tipping load, straight (No tyres deflection)	kg (lbs)	14,400 (31,750)	14,600 (32,190)	14,600 (32,190)	14,350 (31,415)	13,170 (29,035)	-1,350 (-2,975)
Static tipping load, articulated (No tyres deflection)	kg (lbs)	12,500 (27,560)	12,670 (27,930)	12,670 (27,930)	12,450 (27,450)	11,430 (25,200)	-1,300 (-2,865)
Breakout force	kg (lbs)	16,670 (36,750)	17,705 (39,030)	17,705 (39,030)	16,670 (36,750)	13,870 (30,580)	-240 (-530)
Operating weight*	kg (lbs)	19,450 (42,880)	19,375 (42,710)	19,375 (42,710)	19,500 (42,990)	19,840 (43,740)	+830 (+1,830)

* All height and tyre related dimensions are with standard 23.5 R25, L3 tyres.

DENSITY AND BUCKET SELECTION

DENSITY OF OPERATING MATERIALS

Loose Material	Material Density [ton / m³]	
Earth/Clay	1.5 ~ 1.7	
Sand and Gravel	1.5 ~ 1.7	
Aggregate	25 ~ 76 mm (1 to 3 in)	1.6 ~ 1.7
	19 mm (0.75 in) and larger	1.8

HL960A / HL960AHD BUCKET SELECTION CHART

Standard lift arm, General Purpose													
Type	m³ (yd³)	Material Density [t/m³]											
		1.1	1.2	1.3	1.4	1.5	1.6	1.7	1.8	1.9	2.0	2.1	2.2
Cutting edge	3.3 (4.32)	3.8 m³ (4.97 yd³)						3.1 m³ (4.5 yd³)					
1-Bolt on tooth	3.2 (4.19)	3.7 m³ (3.84 yd³)						3.0 m³ (3.92 yd³)					
2-Bolt on tooth	3.2 (4.19)	3.7 m³ (4.84 yd³)						3.0 m³ (3.92 yd³)					
2-Bolt on tooth & SEG	3.3 (4.32)	3.8 m³ (4.97 yd³)						3.1 m³ (4.5 yd³)					
Cutting edge Q/C	3.3 (4.32)	3.8 m³ (4.97 yd³)						3.1 m³ (4.5 yd³)					
High lift arm, General Purpose													
Type	m³ (yd³)	Material Density [t/m³]											
		1.1	1.2	1.3	1.4	1.5	1.6	1.7	1.8	1.9	2.0	2.1	2.2
Cutting edge	3.3 (4.32)	3.8 m³ (4.97 yd³)						3.1 m³ (4.5 yd³)					
1-Bolt on tooth	3.2 (4.19)	3.7 m³ (3.84 yd³)						3.0 m³ (3.92 yd³)					
2-Bolt on tooth	3.2 (4.19)	3.7 m³ (4.84 yd³)						3.0 m³ (3.92 yd³)					
2-Bolt on tooth & SEG	3.3 (4.32)	3.8 m³ (4.97 yd³)						3.1 m³ (4.5 yd³)					
Cutting edge Q/C	3.3 (4.32)	3.8 m³ (4.97 yd³)						3.1 m³ (4.5 yd³)					

Fill factor

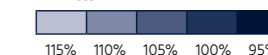

DENSITY AND BUCKET SELECTION

CHANGE IN OPERATING SPECIFICATIONS - TYRES			
Tyres		23.5 R25, *, XHA	23.5-25 Solid Tyre
Operating Weight(kg)	kg	-150	2,290
	lb	-330	5,050
Static Tipping Load. Straight (No Tire Deflection)	kg	-110	1,670
	lb	-240	3,680
Static Tipping Load. Articulated (No Tire Deflection)	kg	-95	1,440
	lb	-210	3,170
Vertical Height Changes	mm	-10	30
	ft/in	-0.39"	1.18"
R. Width Over Tyres (Unloaded)	mm	-2	6
	ft/in	-0.07"	+0.24"
P. Clearance Circle (Diameter) to Outside of Tyres	mm	-2	6
	ft / in	-0.07"	+0.24"
Q. Clearance Circle (Diameter) to Inside of Tyres	mm	+2	-6
	ft/in	+0.07"	-0.24"

* Dimension changes compared to 23.5R25 L3 radial tyres.

OVERVIEW						
Description		HL960A	HL960AXT	HL960AHD	HL960AHDXT	
Operating weight	kg	19,200	20,030	19,450	20,280	
	lb	42,330	44,160	42,880	44,710	
Bucket capacity	Heaped	m ³	3.3	3.3	3.3	3.3
		yd ³	4.3	4.3	4.3	4.3
	Struck	m ³	2.9	2.9	2.9	2.9
		yd ³	3.8	3.8	3.8	3.8
Breakout force-bucket	kg	16,670	16,430	16,670	16,430	
	lb	36,750	36,220	36,750	36,220	
Tipping load	Straight	kg	14,300	12,950	14,400	13,050
		lb	31,525	28,550	31,750	28,770
	Full turn	kg	12,410	11,110	12,500	11,200
		lb	27,360	24,495	27,560	24,690

CABIN & INTERIOR	STD
ALARMS, AUDIBLE AND VISUAL	
Air Filter Clogging	●
Battery Voltage	●
Brake Oil Pressure	●
Def Low Level	●
Engine Coolant Level	●
Engine Oil Pressure	●
Fuel Level	●
Hydraulic Oil Temperature	●
Engine Coolant Temperature	●
Parking Brake	●
Service Brake Oil Pressure	●
Seat Belt On/Off	●
Transmission Error	●
Transmission Oil Temperature	●
Alarm, Back-Up	●
BATTERIES	
900 CCA, 12 V, 2 PCS	●
GAUGES	
Diesel Exhaust Fluid (Def) Level	●
Engine Coolant Temperature	●
Fuel Level	●
Speedometer	●
Transmission Oil Temperature	●
Horn, Electric	●
INDICATOR LIGHTS	
Differential Lock	●
Fnr Joystick Steering	●
High Beam	●
Pilot Cut Off	●
Turn Signal	●
LCD DISPLAY	
Clock And Fault Code	●
Engine Rpm	●
Indicator	●
Job Time And Distance	●
Operating Hour Counter	●
Transmission Gear Range	●
Temperature (Coolant, Hydraulic Oil, T/M Oil)	●
LIGHTING SYSTEM	
Brake Lights (Counterweight)	●
Led Dome Light	●
2 Stop and Tail Lights	●
4 Turn Signals	●
2 Head Lights on Front Tower	●
2 Head Lights (Led) on Front Tower	●
2 Working Lights on Front Roof	●
4 Working Lights on Front Roof	●
2 Working Lights on Rear Roof	●
4 Working Lights (Led) on Front Roof	●
2 Working Lights (Led) on Rear Roof	●
2 Working Lights on Grill	●
2 Working Lights (Led) on Grill	●
SWITCHES	
Battery master switch	●
Differential Lock	●
Engine Hood Open	●
Fnr Shifter	●
Hazard	●
Parking	●
Pilot Cut Off	●
Selective Catalytic Reduction	●
Secondary Steering	●
MEMBRANE SWITCHES IN MONITOR	
Main Light	●
Work Light	●
Auto Grease	●
Quick Coupler	●
Ride Control	●
Work Load	●
Beacon Light	●
Rear Wiper	●
Mirror Heat	●
Auto Position	●
Fine Modulation	●
IGNITION	
Key	●
Button	●
CABIN (SOUND SUPPRESSED)	
Cigar Lighter & Ashtray	●
Coat Hook	●

CABIN & INTERIOR	STD
AUTOMATIC CLIMATE CONTROL	
Air Conditioner & Heater	●
Defroster	●
Intermittent Wiper And Washer, Front And Rear	●
SEAT	
2" Retractable Seat Belt & Adjustable Mechanical Suspension (Heated)	●
2" Retractable Seat Belt & Adjustable Air Suspension (Heated)	●
PERSONAL STORAGE SPACE	
Console Box	●
Holder, Can and Cup	●
Rear View Mirrors (1 Inside)	●
Rear View Mirrors (2 Outside, Heated)	●
Steering Column, Tilt And Telescopic	●
Steering Wheel With Knob	●
Roller Type Sunshade (Front Window)	●
Roller Type Sunshade (Rear Window)	●
Tinted Safety Glass	●
One Door Cab	●
Magazine Pocket	●
PEDALS	
One Accelerator Pedal	●
One Brake Pedal	●
Dual-Brake Pedal	●
Accel Pedal Without ECO Switc	●
Accel Pedal With ECO Switch	●
Radio / Usb Player	●
Rubber Floor Mat	●
Wrist Rest	●
24 V To 12 V Dc Converter (20 A)	●

ENGINE	STD
Alternator, 95A	●
Antifreeze	●
ENGINE, CUMMINS, B6.7	
EU Stage V / EPA Tier 4 Final	●
Engine Enclosure, Lockable	●
Fuel / Water Separator	●
Engine Oil Level Dipstick Gauge	●
CLEAN EMISSION MODULE	
DOC, SCR, DPF	●
Fuel Warmer	●
Fan Guard	●
Rain Cap, Engine Air Intake	●
Coolant Level Sight Gauge	●
3 Stage Air Precleaner	●

POWER TRAIN	STD
TRANSMISSION	
Transmission F4/R3, Computer Controlled, Electronic Soft Shift, Auto-Shift and Kick-Down Features Included	●
Transmission F5/R3 With Lock-Up Clutch	●
Transmission F5/R3 With Thermostat	●
Transmission Oil Sight Level	●
AXLE	
Open Differential (Rear)	●
Limited Slip Differential (Front / Rear)	●
Hydraulic Lock Differential (Front)	●
Axle Cooling System	●
BRAKE	
Service Brake (Enclosed Wet-Disc)	●
Parking Brake	●
TYRES	
23.5 R25, L3	●
23.5 R25, XHA2	●

SAFETY	STD
Fire Extinguisher	●
Boom Safety Lock	●
Emergency Steering	●
OBJECT DETECTION	
IMOD(Intelligent Moving Object Detection)	●
AVM(Around View Monitoring)	●
RADAR	●
ROPS / FOG CAB.	●

HYDRAULIC SYSTEM	STD
Auto Grease System	●
Boom Kickout, Automatic	●
Bucket Positioner, Automatic	●
Diagnostic Pressure Taps	●
EH Control (Joystick)	●
EH Control (Fingertip)	●
EH Joystick Steering	●
Hyundai Bio Hydraulic Oil (Hbho)	●
Hydraulic Oil Level Sight Gauge	●
Quick Coupler Piping	●
Ride Control System	●
Secondary Steering System	●

WASTE HANDLING PACKAGE (HL960AHD)	STD
AXLE	
Hydraulic Lock Differential - HD (Front)	●
Open Differential - HD (Rear)	●
FULL GUARDS	
MCV (Machine Control Valve)	●
Bucket Cylinder	●
Cabin Glass (Front / Rear)	●
Head Lamp	●
Rear Combi-Lamp	●
Work Light (Rear)	●
Radiator	●
Attachment Hydraulic Hose	●
TYRE	
SOLID (23.5-25)	●

OTHER	STD
Articulation Locking Bar	●
Air Compressor	●
ATTACHMENTS	
3.3 m ³ Bucket, Cutting Edge	●
3.2 m ³ Bucket 1-Bolt-on Tooth Type	●
3.2 m ³ Bucket 2-Bolt-on Tooth Type	●
3.3 m ³ Bucket, Cutting Edge Q/C Type	●
3.3 m ³ Bucket 2-Bolt-on Tooth & Segment Edge Type	●
Quick Coupler	●
Counterweight	●
Counterweight - Heavy Weight	●
Door and Cab Locks, One Key	●
Doors, Service Access (Locking)	●
Doors, Service Access (Remote Control)	●
Remote Cabin Door	●
Drawbar With Pin	●
ERGONOMICALLY LOCATED AND SLIP RESISTANT, LEFT & RIGHT	
Handrails	●
Ladders	●
Platforms	●
Steps	●
Lift and Tie-Down Hooks	●
Loader Linkage, Sealed	●
Z-Bar Design	●
Vandalism Protection Caplocks	●
TELEMATICS	
Hi-Mate	●
ECD (Engine Connected Diagnostics)	●
Tool Kit	●
GUARDS	
Crankcase	●
Transmission	●
Fenders (Front / Rear)	●
Mud Guards (Rear)	●
Cabin Glass (Front / Rear)	●

* Standard and optional equipment may vary. Contact your Hyundai dealer for more information. The machine may vary according to International standards.
 * The photos may include attachments and optional equipment that are not available in your area.
 * Materials and specifications are subject to change without advance notice.
 * All imperial measurements rounded off to the nearest pound or inch.

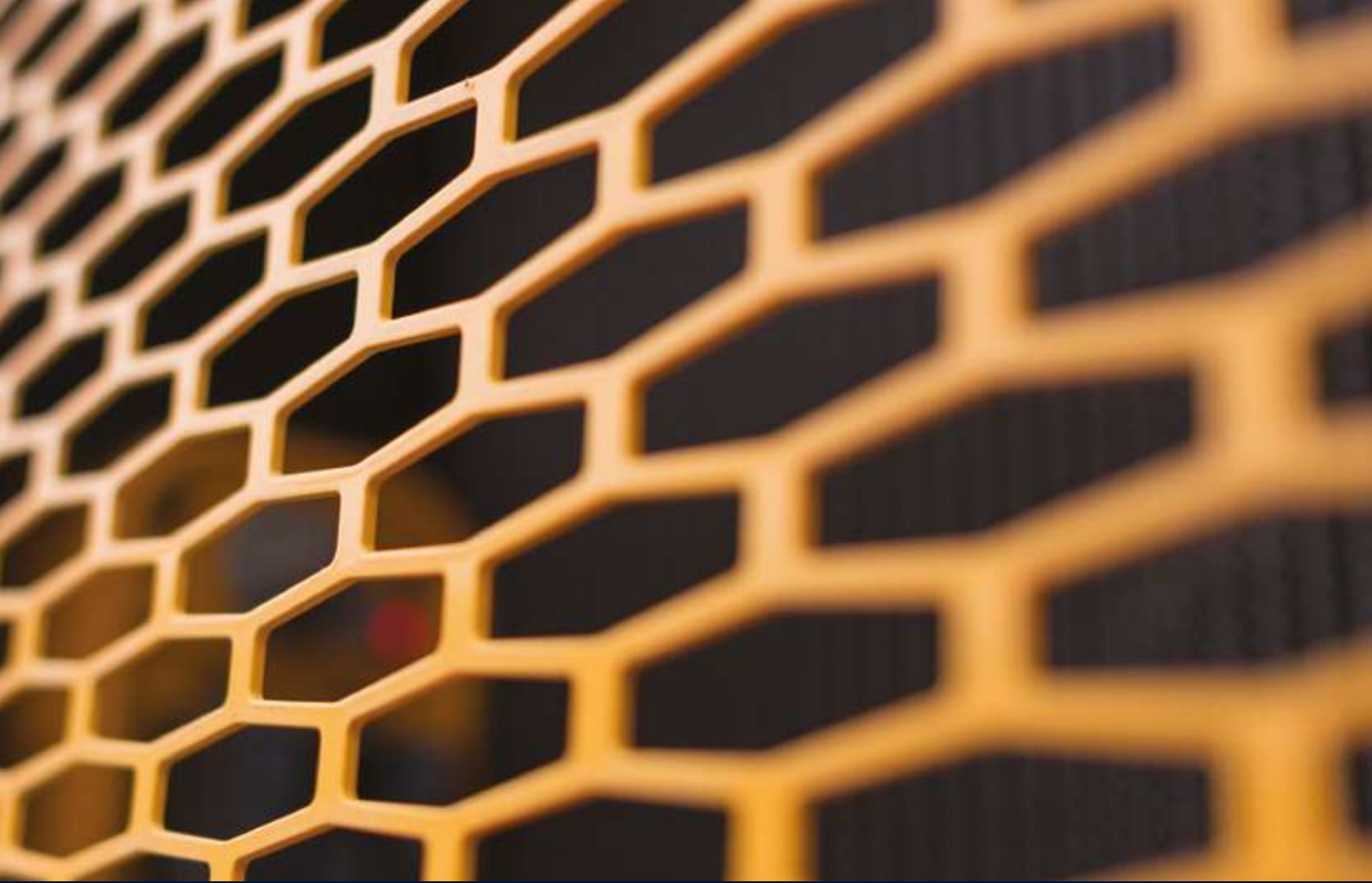

Specifications and design are subject to change without notice. Pictures of Hyundai Construction Equipment Europe products may show other than standard equipment.

The images in this brochure show both HL960A and HL96AHD versions. Please ask your dealer for more information.

Hyundai Construction Equipment Europe nv, Hyundailaan 4, 3980 Tessenderlo, Belgium. Tel: (32) 14-56-2200 Fax: (32) 14-59-3405

EN – 2020.01 Rev 2

Ready to experience the Hyundai Effect?

Contact your Hyundai dealer.
hyundai-ce.eu/en/dealer-locator

