

WHEEL LOADER
HL980A
HL980AXT





READY TO CHANGE YOUR WORLD

The HL980A Wheel Loader is part of Hyundai's brand new A-Series: a fresh generation of construction equipment that complies with European stage V emission levels. But it goes much further than that! While fulfilling regulatory demands, Hyundai aimed for a ground-breaking level of customer satisfaction with maximum performance and productivity, better safety, more convenience and improved uptime management.

Featuring impressive power matched with carefully selected technologies that help you to work more efficiently and economically, this 31-tonne loader opens up a world of new possibilities. It's time to experience the Hyundai Effect!

ENTER A WORLD WHERE ANYTHING IS POSSIBLE



Productivity

- Load sensing hydraulic system
- Accurate weighing system
- Eco Report
- Smart Power mode
- Hydraulic differential lock
- 5-speed transmission with lock-up clutch
- Intelligent clutch cut-off (ICCO)
- Automatic engine shutdown
- Optimised power matching

Durability/Safety

- Emergency stop switch
- AAVM camera system (option)
- Radar rear detection (option)
- IMOD (Intelligent Moving Object Detection) (option)
- Enhanced axle capacity
- Axle cooling (option)
- Thermostat-based transmission cooling
- Optimised drive shaft
- Completely sealed engine room
- High grade hoses
- Foldable side mirror
- Seat belt warning alarm

Comfort

- Spacious soundproofed cabin
- Fully adjustable seat and armrest
- Air compressor (option)
- Wide touchscreen monitor
- Ride control system
- Fully adjustable seat and armrest
- Remote door control (option)
- Soft end stop

Serviceability

- ECD (Engine Connected Diagnostics)
- Fully openable engine hood
- Hi-MATE telematic system
- Easy filter replacement
- Auto greasing system (option)
- Wide core & fin radiator

PROTECT YOUR CO-WORKERS AND EQUIPMENT

Details can make a huge difference when it comes to safety, especially if you're working in rough conditions. It's not just a matter of complying with rules. The HL980A's safety features are designed and tested to meet your needs in the real world, even offering an extra pair of eyes with the optional Advanced Around View Monitoring (AAVM) and radar systems. Operating confidence is maximised with technologies that provide a feeling of stability and smooth performance in high-load work. By helping to ensure a calm, accident-free worksite, this wheel loader adds to the productivity and peace of mind that are all part of the Hyundai Effect.

"It looks tough but its performance is surprisingly smooth and predictable. In this machine, I feel safe in any conditions."

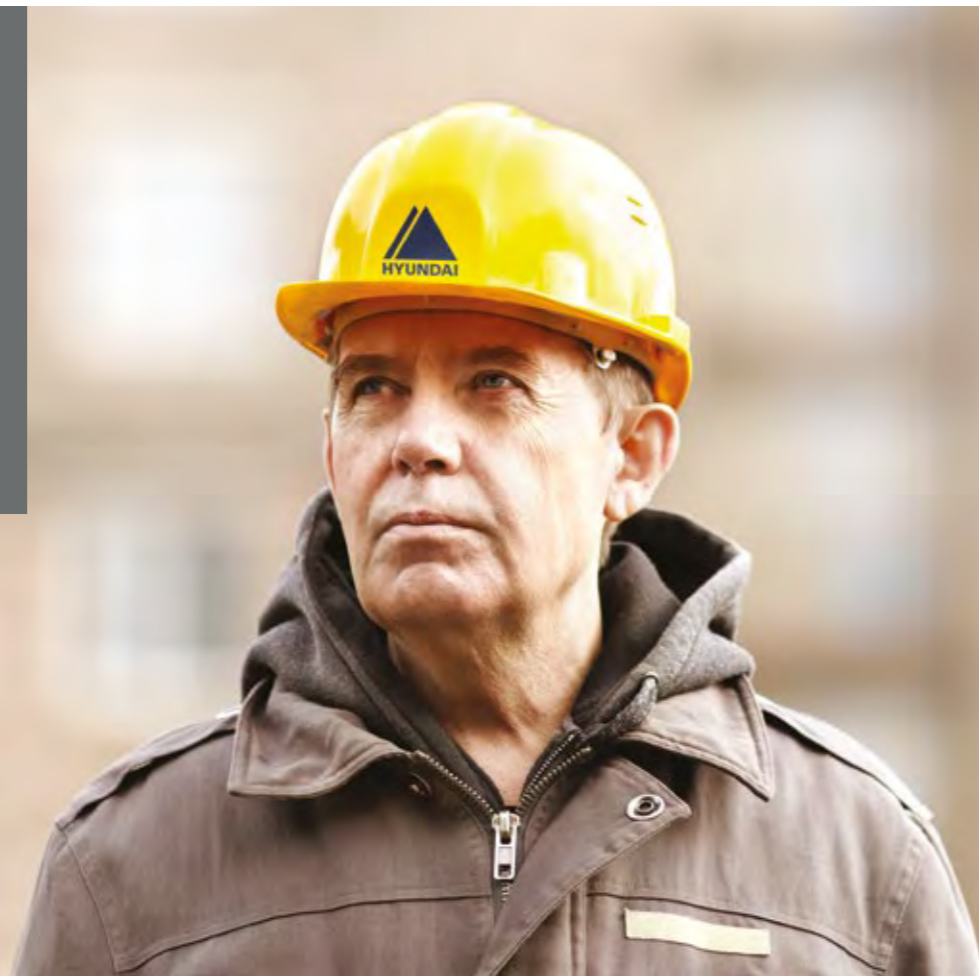

A **ride control system** with a piston accumulator reduces pitching of the wheel loader body and bucket for smooth, stable and comfortable operation. It also minimises spillage, improving productivity.

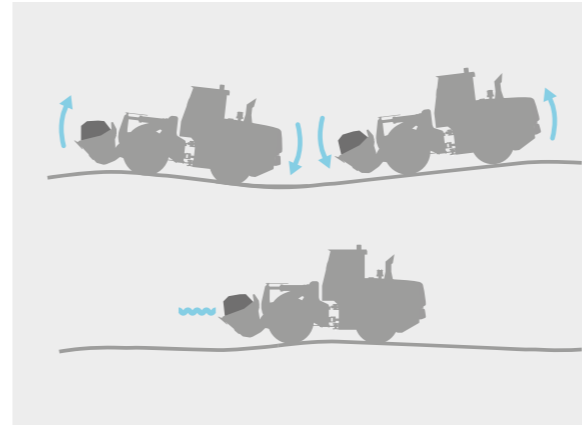

A **hydraulic locking differential** prevents tyre slip for better productivity and fuel economy.

The optional **Advanced Around View Monitoring (AAVM)** system gives you a 360° overview of your immediate working environment. It also includes Intelligent Moving Object Detection (IMOD) technology that senses and warns you when people or objects come within five metres of the machine.

The heated **side mirror** is easy to adjust for optimal visibility and can be folded away to prevent damage during transportation.

The optional **radar system** detects obstacles behind the machine, day and night, with no blind spots. The distance between the obstacle and the loader is displayed on the secondary monitor.

Operators are reminded to fasten their **safety belt** by an **audible and visible alarm**.

The engine can be shut down immediately using an **emergency stop switch** located at the base of the seat.



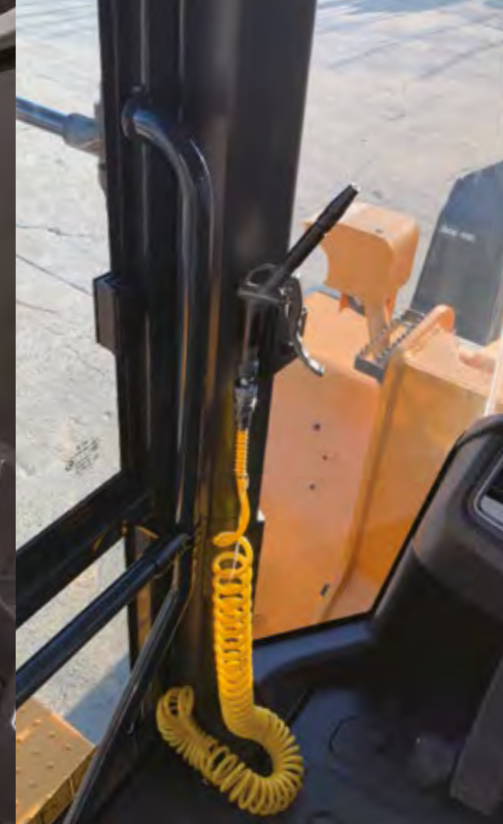

The HL980A has a **large, air suspended, comfortable seat** with heating as standard. The seat and armrest are fully adjustable.

An optional **air compressor** can be mounted in the cabin to help operators keep their workspace pleasant and comfortable.

The **remote door control** option further improves convenience and safety.

A CABIN DESIGNED AROUND YOU

The HL980A cabin was designed to be a perfect fit for every operator and provides a productive, stress-free working environment. Pleasant and spacious, it features state-of-the-art noise and vibration reduction technology, achieving a sound level of only 72 dB, one of the lowest in this machine category. The fully adjustable seat and armrest ensure comfortable reach to all controls. A range of technologies enable easier machine monitoring, while the audio system includes radio, USB and AUX input to keep you entertained during your working day.



The seven-inch **touchscreen monitor** offers excellent legibility.



The **soft end stop** function reduces the hydraulic speed of the cylinder as it reaches the end of its stroke. This lessens the shock load of the stroke for increased operating comfort and better material retention.

The **Eco Report** feature displays real-time information about machine performance to help operators develop efficient working habits.

All the indicators displaying **machine status** are centralised in one cluster to enable easy, efficient control.

“The seat and armrest can be easily adapted for the most comfortable working position. I’m more relaxed on the job, which means I can work longer without getting tired.”



TAILORED TECHNOLOGIES FOR BETTER PRODUCTIVITY

The HL980A's reliable Cummins X12 Stage V engine delivers all the power you need to tackle heavy-duty work in extreme conditions. It is complemented by a range of technologies that increase fuel efficiency while keeping harmful emissions to a minimum.

Precise operating systems help you to get the most out of this mighty machine, including optimised power

matching for the ultimate balance of torque and RPM. When operated in Power Smart mode, the engine delivers significant fuel savings as well as smooth performance in high-load work such as digging. Hyundai's proprietary weighing system technology is integrated as standard. Additional control, monitoring and maintenance features help you to maximise performance and productivity every single day, on any worksite.



The HL980A features our **all-in-one, switch back type exhaust aftertreatment system** which cuts emissions and operating costs while enhancing reliability and simplifying maintenance.



The highly accurate **automatic/manual cumulative weighing system** helps you to manage production more efficiently in any environment. For maximum precision, weighing error icons and a two-colour weight value indicator are displayed on the monitor.



The new **Smart Power mode** adjusts engine RPM in heavy load work like digging to save fuel without compromising on performance. The technology also achieves an optimal balance between traction and breakout forces.



The **engine shuts down automatically when the machine is at rest** to cut fuel consumption and prevent unnecessary emissions. Different operating modes and idling times can be selected according to the work environment, further enhancing efficiency.

The HL980A is equipped with a **five-speed transmission and lockup clutch**. This allows you to work more efficiently while keeping fuel consumption and emissions low.



The **hydraulic locking differential** option prevents tyre slip, making operation more secure while also improving productivity and fuel economy.

"I don't have to worry about emissions regulations and I have all the power I need right at my fingertips."





MORE UPTIME FOR A SUSTAINABLE RETURN ON YOUR INVESTMENT

To protect your profits you need to know that the investment you make today will continue to support your business over the long term. That's why we prioritised reliability throughout the development of the HL980A, from design and manufacturing to

quality control. All operating systems have been optimised for endurance and tested rigorously on a range of work sites. The result is a tough, durable workhorse that requires minimal time for repairs and maintenance.

"The HL980A is built for the long haul. You can see that every system has been tailored for rock-solid reliability."

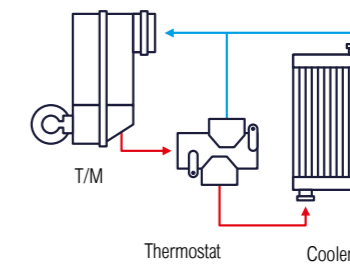

The HL980A is equipped with a **thermostat for transmission cooling**. This feature helps to warm up the fluid quickly and keeps it at the optimal working temperature, protecting components and increasing efficiency.

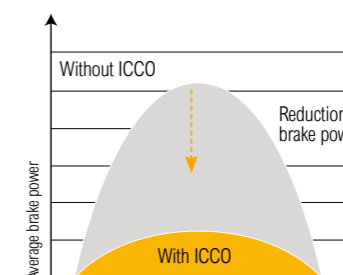

The **Intelligent Clutch Cut-Off (ICCO)** function minimises loss of power in the torque converter and prevents excessive power use during braking. This reduces heat generation and wear on the brake disc.

The HL980A has **axles with extra load capacity** for better reliability and durability. A separate **axle oil cooling system** is available as an option to prevent overheating during high-load work or tasks requiring frequent braking.

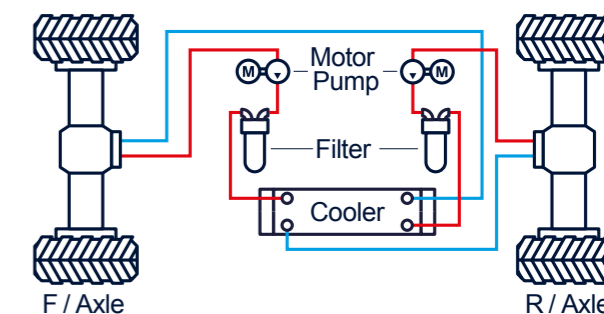

High-grade hoses with outstanding resistance to heat and pressure provide maximum durability, even in rough working conditions.

EASY SERVICING FOR TROUBLE-FREE OWNERSHIP

The peace of mind that comes with quick, low-effort servicing is an important part of what we call the Hyundai Effect. The HL980A has been optimised in numerous ways to make maintenance as convenient as possible. The engine hood opens wide to provide easy access for cleaning and routine tasks. All components and materials have been selected for a long, trouble-free life. Hyundai's Hi-MATE remote management system can be integrated as an option to provide the highest level of service and support. The HL980A also features our new Engine Connected Diagnostics (ECD) system which immediately reports any engine failure to both Hi-MATE and the engine manufacturer to ensure the fastest, easiest resolution.

HiMATE

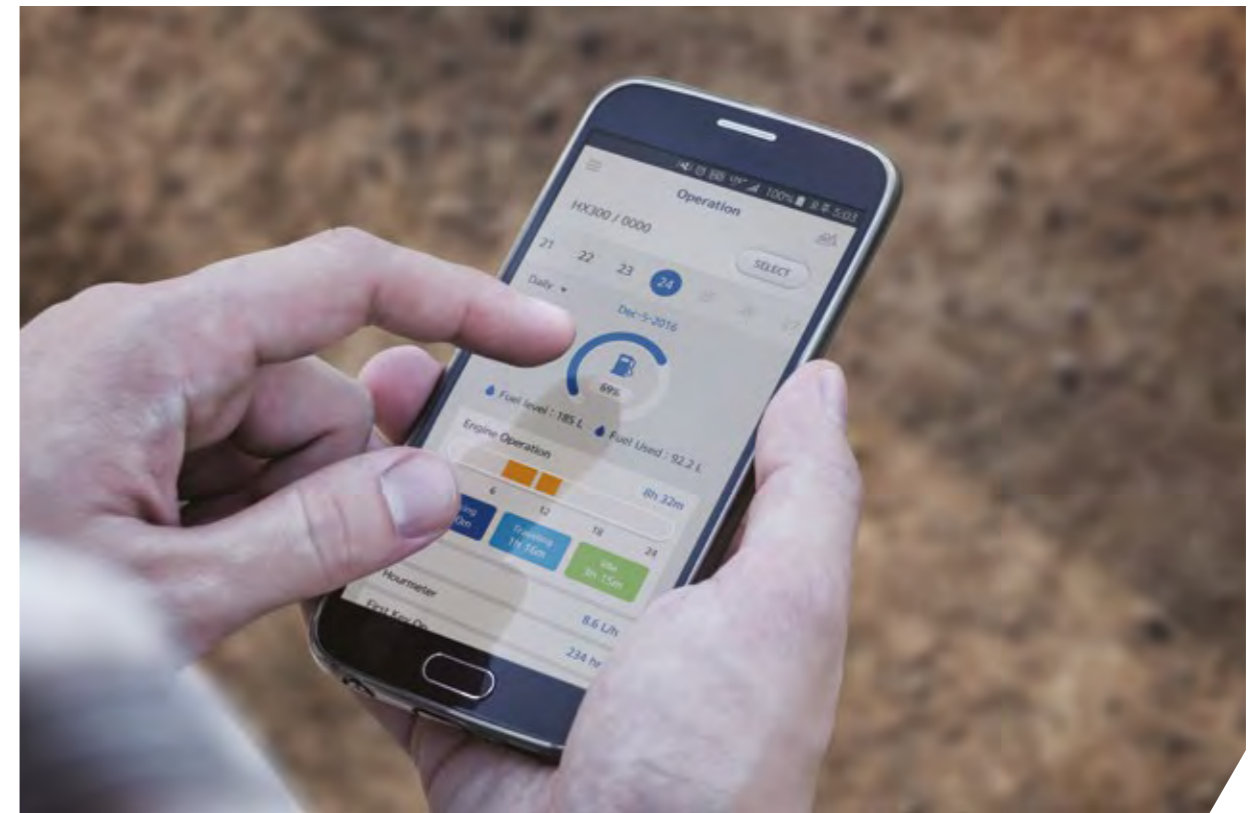

Hyundai's exclusive Hi-MATE remote management system allows you to monitor your machines from any location via a dedicated website or mobile app, with access to diagnostics and working parameters like total engine hours, actual working hours and fuel consumption. The system makes it easy to evaluate machine productivity and plan servicing and maintenance tasks, as well as any required cost-saving measures. It also offers geofencing to protect your machines against theft and unauthorised usage.



With the optional **auto greasing system**, grease is applied to lubrication points automatically when needed. The correct dosing is ensured and lubricant is applied uniformly, reducing grease consumption and eliminating waste.



The **engine hood is fully retractable** and can be **opened electrically** for easy access to the sealed engine room and cooling room. The engine room is designed to prevent the possibility of fire caused by the inflow of foreign materials.



The **air conditioning filter** is easy to replace and is made from a specially selected material for superior performance.



The HL980A has a dependable **wide-core and fin air cooler** that prevents performance degradation caused by contamination.

FOCUSED TECHNOLOGIES FOR THE RESULTS YOU WANT

Hyundai's A-Series wheel loaders are designed to create better conditions for operators and deliver the ultimate ownership experience. Every detail is carefully fine-tuned to match your needs in the field, including better safety and comfort, higher productivity, maximum uptime and easy servicing. This is all part of the Hyundai Effect.

See more at hyundai-ce.eu



SPECIFICATIONS

ENGINE	
Maker / Model	CUMMINS / X12 / EU Stage V
Aftertreatment technology	Wastegate turbocharger DOC/ DPF/ SCR
Type	6 cylinder, Watercooled, 4-cycle, turbocharged charge aircooled, direct injection, electronic controlled diesel engine.
Gross Power (SAE J1995)	355 HP (265 kW) at 2,000 rpm
Net Power (SAE J1349)	351 HP (262 kW) at 2,000 rpm
Max. Power	380 HP (283 kW) at 1,700 ~ 1,800 rpm
Peak Gross Torque (SAE J1995)	1,857 Nm (1,370 lb.ft) at 1,400 rpm
Displacement	11.8 l (720 cu in)

TRANSMISSION					
Travel speed	4 speed T/M		5 speed T/M with lock up clutch		
	km/h	mph	km/h	mph	
Forward	1st	6.2	3.9	6.2	3.9
	2nd	11.6	7.2	11.9	7.4
	3rd	18.2	11.3	18.5	11.5
	4th	36.5	22.7	27.1	16.8
	5th	/	/	40.0	24.9
Reverse	1st	6.2	3.9	6.2	3.9
	2nd	11.6	7.2	11.9	7.4
	3rd	25.3	15.7	27.1	16.8

* This is the maximum travel speed of a standard machine with unfilled bucket.

AXLES	
Drive system	Four-wheel drive system
Front	Fixed
Rear	Oscillating ±11 degrees
Hub reduction	Planetary reduction at wheel end
Differential	Conventional
Reduction ratio	27.0

TYRES	
Type	Tubeless, loader design tyres
Standard	29.5R25 L3 **
Options include	29.5-25, 22PR L3
	29.5-25 28PR L5
	29.5R25 XHA *

BRAKES	
Service Brakes	Hydraulically actuated, wet disc brakes actuate all 4 wheels independent axle-by-axle system. Self adjusting & wheel speed brake
Parking Brake	Spring-applied, hydraulically released brake
Emergency Brake	When brake oil pressure drops, indicator light alerts operator and parking brake automatically applies

AIR CONDITIONING SYSTEM	
The air conditioning system of this machine contains fluorinated greenhouse gas refrigerant R134a (GWP = 1430). The system contains 0.75 kg of refrigerant (1.07 metric tonne CO ₂ equivalent).	

HYDRAULIC SYSTEM		
Type	Load sensing hydraulic system	
Pump	Variable displacement piston pump 420 lpm	
Control valve	2 spool (Bucket, Boom) 3 spool (Bucket, Boom, Aux)	
System pressure	280 bar (4,061 psi)	
Lift Circuit	The valve has four functions: Raise / Hold / Lower / Float Can adjust automatic kickout from horizontal to full lift.	
Tilt Circuit	The valve has three functions: Tilt back / Hold / Dump Can adjust automatic bucket positioner to desired load angle.	
Cylinder	Type: double acting	
	No. of cylinders-bore × stroke	
	Lift	2-180 × 885 mm (2-7.1' × 2' 10.8")
	Bucket Cylinder	1-200 × 550 mm (1-7.9' × 1' 9.7")
	Bucket Cylinder (XT)	1-200 × 545 mm (1-7.9' × 1' 9.5")
Hydraulic Cycle Time with Rated Payload	Raise from Carry Position: 6.6 Sec. Dump, at maximum raise: 1.5 Sec. Lower, empty, float down: 4.8 Sec. Total: 12.9 Sec.	

STEERING SYSTEM	
Type	Load sensing hydrostatic articulated steering
Pump	Variable displacement piston pump
System pressure	210 bar (3,046 psi)
Cylinder	Double acting 2 - 105 mm (4.1") x 460 mm (18.1")
Steering angle	40° to both right and left angle, respectively
Features	Center-point frame articulation Tilt and telescopic steering column

SERVICE REFILL CAPACITIES		
UNIT	l	US gal
Fuel tank	430.0	113.6
DEF tank	44.5	11.8
Cooling system	45.5	12.0
Crankcase	34.0	9.0
Transmission	55.0	14.5
Front axle	64.0	16.9
Rear axle	64.0	16.9
Hydraulic tank	184.0	40.5
Hydraulic system (Including tank)	340.0	74.8

CABIN	
ROPS / FOPS meet ISO 3471 and ISO 3449	

SOUND	
Guaranteed noise level presented below can be differed depending on a range of factors such as operating condition, speed of a cooling fan, types of engine and so forth. Hearing protection shall be necessary if an operator is working in the improperly maintained cabin or exposed to a noisy environment by leaving doors and/or windows open.	
With Cooling Fan Speed at Maximum Value:	
Operator Sound Pressure Level (ISO 6396:2008)	72 dB(A)
Exterior Sound Power Level (ISO 6395:2008)	108 dB(A)

* Distance of 15 m (49.2 ft), moving forward in second gear ratio.

DIMENSIONS

HL980A DIMENSIONS

All dimensions are approximate.

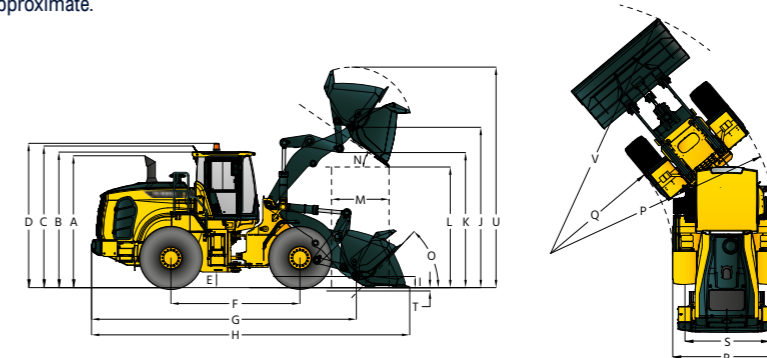

Description	HL980A		HL980AXT	
	mm	ft in	mm	ft in
A. Height to Top of Exhaust Pipe	3,715	12'2"	3,715	12'2"
B. Height to Top of Cabin	3,865	12'8"	3,865	12'8"
C. Height to Top of Product Link Antenna	3,905	12'10"	3,905	12'10"
D. Height to Top of Warning Beacon	3,995	13'1"	3,995	13'1"
E. Ground Clearance	495	1'7"	495	1'7"
F. Wheelbase	3,700	12'2"	3,700	12'2"
G. Overall Length (Without Bucket)	8,175	26'10"	8,495	27'10"
H. Shipping Length (With Bucket Level on Ground)	9,610	31'6"	9,930	32'7"
I. Hinge Pin Height at Carry Position	535	1'9"	630	2'1"
J. Hinge Pin Height at Maximum Lift	4,615	15'2"	4,935	16'2"
K. Lift Arm Clearance at Maximum Lift	3,870	12'8"	4,190	13'9"
L. Dump Clearance at Maximum Lift and 45° Discharge	3,300	10'10"	3,620	11'11"
M. Reach at Maximum Lift and 45° Discharge	1,490	4'11"	1,525	5'0"
N. Dump Angle at Maximum Lift and Dump (on Stops)	50		50	
O. Roll Back Angle	Ground	42	42	
	Carry	47	47	
P. Clearance circle (diameter) to outside of tyres	13,615	44'8"	13,615	44'8"
Q. Clearance Circle (diameter) to Inside of tyres	7,110	23'4"	7,110	23'4"
R. Width over tyres (unloaded)	3,190	10'6"	3,190	10'6"
S. Tread Width	2,440	8'0"	2,440	8'0"

OPERATING SPECIFICATIONS WITH BUCKETS

Linkage Bucket Type	Standard Linkage General Purpose – Pin On						High Lift Linkage Change
	Bolt-On Cutting Edges	2 Piece Tooth	2 Piece Tooth & Seg	Bolt-On Cutting Edges	2 Piece Tooth	Spade Nose Rock	
Capacity - rated	m ³	5.60	5.40	5.60	6.30	6.10	5.00
	yd ³	7.30	7.10	7.30	8.20	8.00	6.50
Capacity - rated at 110% fill factor	m ³	6.16	5.94	6.16	6.93	6.71	5.50
	yd ³	8.10	7.80	8.10	9.10	8.80	7.20
Width	mm	3,450	3,500	3,500	3,450	3,500	3,490
	ft/in	11'4"	11'6"	11'6"	11'4"	11'6"	11'5"
Dump clearance at maximum lift and 45° discharge	mm	3,300	3,150	3,150	3,215	3,065	3,035
	ft/in	10'10"	10'4"	10'4"	10'7"	10'1"	9'11"
Reach at maximum lift & 45° discharge	mm	1,490	1,610	1,610	1,575	1,695	1,685
	ft/in	4'11"	5'3"	5'3"	5'2"	5'7"	5'6"
Digging depth	mm	105	125	125	105	125	155
	ft/in	0'4"	0'5"	0'5"	0'4"	0'5"	0'6"
Shipping length (with bucket)	mm	9,610	9,800	9,800	9,730	9,920	9,935
	ft/in	31'6"	32'2"	32'2"	31'11"	32'7"	32'7"
Overall height with bucket at maximum lift	mm	6,430	6,430	6,430	6,580	6,580	6,340
	ft/in	21'1"	21'1"	21'1"	21'7"	21'7"	20'10"
Loader clearance circle with bucket at carry position (V)	mm	15,270	15,450	15,450	15,340	15,520	15,320
	ft/in	50'1"	50'8"	50'8"	50'4"	50'11"	50'3"
Static tipping load, straight (No tyres deflection)	kg	23,100	23,500	22,900	22,800	23,200	22,350
	lb	50,930	51,810	50,490	50,270	51,150	49,275
Static tipping load, articulated (No tyres deflection)	kg	20,100	20,450	19,900	19,850	20,200	19,500
	lb	44,315	45,085	43,875	43,765	44,535	42,995
Breakout force	kg	24,670	26,200	24,670	22,800	24,090	22,620
	lb	54,390	57,765	54,390	50,270	53,110	49,870
Operating weight*	kg	30,800	30,635	30,980	30,975	30,810	31,415
	lb	67,905	67,540	68,300	68,290	67,925	69,260

* All height and tire related dimensions are with standard 29.5 R25, L3 tires.

DENSITY AND BUCKET SELECTION

DENSITY OF OPERATING MATERIALS		
Loose Material	Material Density [ton / m ³]	
Earth/Clay	1.5 ~ 1.7	
Sand and Gravel		
Aggregate	25 ~ 76 mm (1 to 3 in)	1.6 ~ 1.7
	19 mm (0.75 in) and larger	1.8

HL980A / HL980AXT BUCKET SELECTION CHART																
Standard lift arm, General Purpose																
Type	m ³	Material Density [t/m ³]														
		1.1	1.2	1.3	1.4	1.5	1.6	1.7	1.8	1.9	2.0	2.1	2.2	2.3	2.4	
Cutting edge	5.6	6.4 m ³									5.3 m ³					
2-Bolt on tooth	5.4	6.2 m ³									5.1 m ³					
2-Bolt on tooth & segment edge	5.6	6.4 m ³									5.3 m ³					
Cutting edge	6.3	7.2 m ³							6.0 m ³							
2-Bolt on tooth	6.1	7.0 m ³							5.8 m ³							
Spade Nose Rock	5.0	5.8 m ³									4.8 m ³					
High lift arm - General Purpose																
Type	m ³	Material Density [t/m ³]														
		1.1	1.2	1.3	1.4	1.5	1.6	1.7	1.8	1.9	2.0	2.1	2.2	2.3	2.4	
Cutting edge	5.6	6.4 m ³									5.3 m ³					
2-Bolt on tooth	5.4	6.2 m ³									5.1 m ³					
2-Bolt on tooth & segment edge	5.6	6.4 m ³									5.3 m ³					
Cutting edge	6.3	7.2 m ³							6.0 m ³							
2-Bolt on tooth	6.1	7.0 m ³							5.8 m ³							
Spade Nose Rock	5.0	5.8 m ³									4.8 m ³					

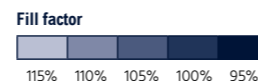

CHANGE IN OPERATING SPECIFICATIONS - TYRES				
Tyres		29.5R25 XHA *	29.5-25 22PR L3	29.5-25 28PR L5
Operating Weight(kg)	kg	-170	-590	660
	lb	-370	-1,300	1,460
Static Tipping Load. Straight (No Tyre Deflection)	kg	-125	-430	480
	lb	-275	-945	1,060
Static Tipping Load. Articulated (No Tyre Deflection)	kg	-110	-380	430
	lb	-240	-835	950
Vertical Height Changes	mm	-14	-4	31
	ft/in	-0.55	-0.16	1.22
R. Width Over Tyres (Unloaded)	mm	-2	30	23
	ft/in	-0.08	1.18	0.91
P. Clearance Circle (Diameter) to Outside of Tyres	mm	-2	30	23
	ft / in	-0.08	1.18	0.91
Q. Clearance Circle (Diameter) to Inside of Tyres	mm	2	-30	-23
	ft/in	0.08	-1.18	-0.91

** Dimension changes compared to 29.5 R25 L3 ★ radial tyres.

OVERVIEW				
Description		HL980A	HL980AXT	
Operating weight	kg	30,800	31,500	
	lb	67,905	69,450	
Bucket capacity	Heaped	m ³	5.60	5.60
		yd ³	7.30	7.30
	Struck	m ³	4.80	4.80
		yd ³	6.30	6.30
Breakout force-bucket	kg	24,670	24,400	
	lb	54,390	53,795	
Tipping load	Straight	kg	23,100	21,650
		lb	50,930	47,735
	Full turn	kg	20,100	18,700
		lb	44,315	41,230



Specifications and design are subject to change without notice. Pictures of Hyundai Construction Equipment Europe products may show other than standard equipment.

Hyundai Construction Equipment Europe nv.
Hyundailaan 4, 3980 Tessenderlo, Belgium.
Tel: (32) 14-56-2200 Fax: (32) 14-59-3405

EN - 2020.04 Rev 1

Ready to experience the Hyundai Effect?

Contact your Hyundai dealer.
hyundai-ce.eu/en/dealer-locator

