

WHEELED EXCAVATORS

HW140A HW160A

Operating weight: 14900 kg & 17580 kg
Engine power: 129 kW (173 HP) / 2200 rpm
Bucket capacity: 0.50 m³ - 0.71 m³ / 0.69 m³ - 1.05 m³



A IM HIGH



Take your performance to the next level!

Hyundai Construction Equipment has raised the benchmark again with a new series of wheeled excavators that give you the edge in numerous on-road and off-road applications. Our A-Series machines comply with EU Stage V emissions regulations while delivering higher performance, better fuel efficiency, superior travel speed on the road, an improved cabin and added safety features.

Featuring a new, compact rear design and enhanced controllability, the HW140A and HW160A are the new class leaders on big and small sites, for trenching, digging, dozing, drilling, cutting, lifting or site preparation. Set your sights on higher efficiency and outstanding results. **Together, we can move mountains!**

Productivity & Efficiency

AIM FOR SUPERIOR PERFORMANCE

... with effortless power.

From their upgraded, eco-friendly engine to their carefully chosen control technologies, our HW140A and HW160A wheeled excavators help operators to achieve new heights of productivity. The load sensing hydraulics and Variable Power Control systems tailor the machine's performance for widely varying needs and working conditions. The compact rear design increases versatility and gives peace of mind to operators.



Hydrostatic 4-wheel drive

The 4-wheel hydrostatic drive system ensures a smooth driving experience, even in rough conditions.



Proportional auxiliary hydraulics

Productivity is further enhanced by a proportional auxiliary hydraulics system. A proportional single or double-acting circuit is installed as standard, enabling smooth, precise control of attachments.



Eco gauge

This feature helps operators to reduce emissions and running costs by constantly monitoring efficiency. It displays engine workload and fuel-saving status while the machine is working.



NEW

High-performance Stage V engine
The HW140A and HW160A are equipped with a fuel-efficient Cummins B4.5 Stage V engine that meets the world's strictest emission regulations. Its compact 4-cylinder configuration delivers impressive power and performance with 31% more peak torque and 5% more peak power than its 6-cylinder predecessor.

7-11% FUEL SAVINGS
depending on working operation

+ 31% PEAK TORQUE

+ 5% PEAK POWER
vs 6-cylinder predecessor

Engine auto-idle

The auto-idle feature saves fuel, reduces noise and cuts exhaust emissions by automatically switching the engine to idle setting when the excavator is inactive. This reduces fuel consumption without affecting productivity.

Advanced exhaust aftertreatment

Our all-in-one exhaust aftertreatment module combines a DOC, SCR and DPF in one unit. EGR-free and featuring DPF auto-regeneration, this simplified system is more robust and requires less maintenance. Removing the need for EGR has also enabled us to improve productivity through better fuel economy and longer service intervals.

Load sensing hydraulic system

Load sensing hydraulics allow for multi-functional operation and precise machine movements. Control is smooth and predictable, even with a demanding workload. By delivering power exactly when needed, the system also contributes to fuel savings.

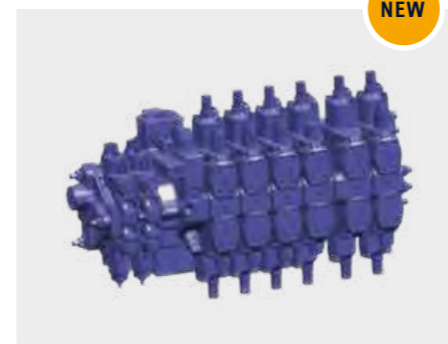

NEW

NEW

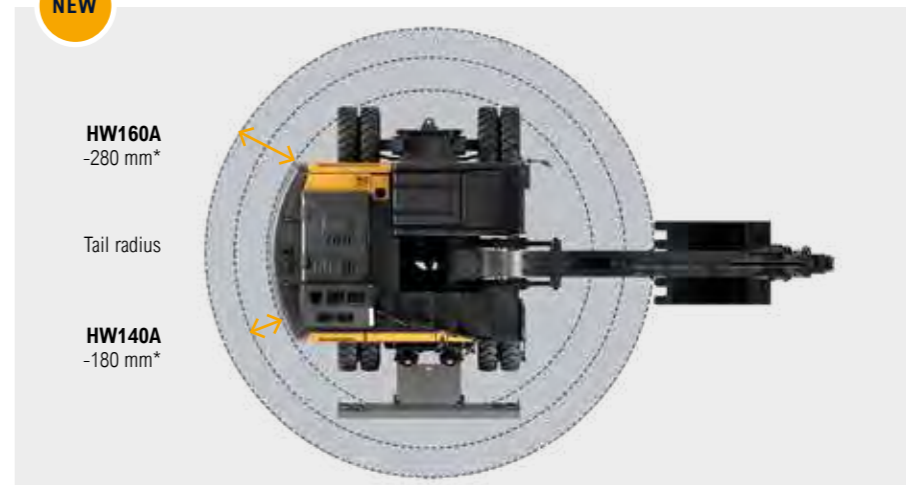

HW160A
-280 mm*

Tail radius

HW140A
-180 mm*

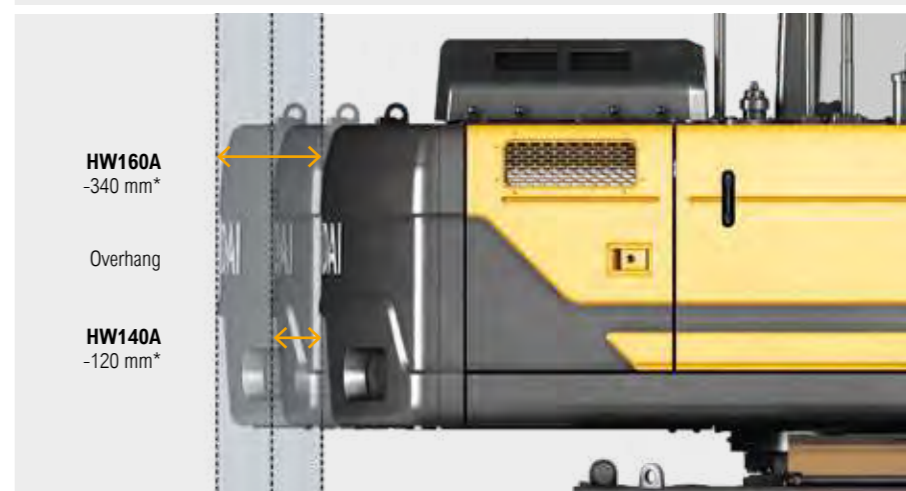

HW160A
-340 mm*

Overhang

HW140A
-120 mm*

*versus predecessor

Productivity & Efficiency

AIM FOR MAXIMUM RETURN ON INVESTMENT

with the flexibility to tackle any job.



Changeable blade & stabilisers

'Plug and play' front and rear stabilisers allow for independent and tailored support according to the work environment. The blade is also fully changeable for increased versatility.



Trailer hitch preparation

The HW140A / HW160A can easily be equipped for the addition of a trailer hitch, giving you the option to transport all necessary tools and machinery to the worksite in one trip. The preparation kit includes electric and hydraulic connectors for rear lights and braking systems.



Electronically controlled reversible fan

The reversible fan is electronically controlled to provide automatic engine cooling. An improved self-cleaning fan mode efficiently eliminates dust and debris, protecting performance and productivity.



Tiltrotator

A factory-mounted Engcon tiltrotator is available as an option, boosting efficiency and profitability through enhanced control with lower fuel consumption.



2D and 3D grading

Your HW140A or HW160A wheeled excavator can be supplied with factory-prepared 2D or 3D-ready Machine Control or Machine Grading systems. This gives you the flexibility to work on a wider range of job sites and applications.

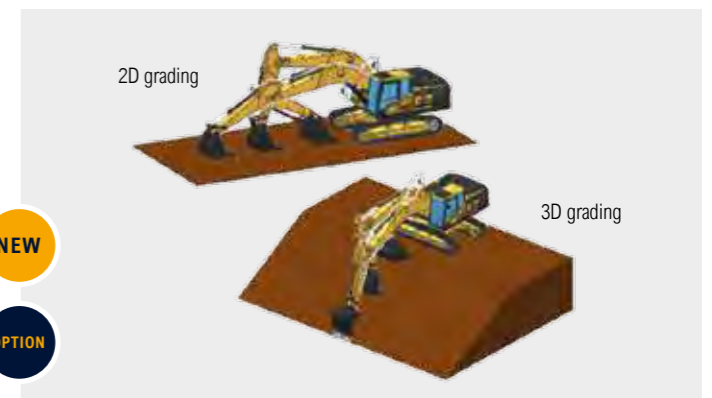

Durability

AIM FOR MORE UPTIME AND DRIVING PLEASURE

... with robust construction and reliable components.

Hyundai has always been driven by the goal of providing durable machines that will create the ultimate long-term ownership experience for our customers. As well as improving engine reliability and simplifying the exhaust aftertreatment system, we have reinforced and optimised numerous other components to extend the lifetime of our A-Series wheeled excavators. Our ultimate aim is to minimise downtime and repairs so that you can stay on schedule, avoid unexpected costs and protect your profits.



Hi-grade (high-pressure) hoses

High-grade hoses with outstanding resistance to heat and pressure provide maximum durability with low maintenance, even in demanding conditions.

Durable cooling module

The HW140A and HW160A are equipped with a new, stacked-type, easy-clean cooling module with a hydraulically driven reversible fan. As well as improving durability, it optimises fuel economy and noise reduction.



Centralised greasing system

A centralised automatic greasing system can be installed as an option. This optimises daily maintenance to prolong the life of all machine joints.

OPTION



Reinforced pins, bushings and polymer shims

The reinforced pins, bushings and polymer shims are designed for an extended lifetime with less maintenance, reducing overall ownership costs.

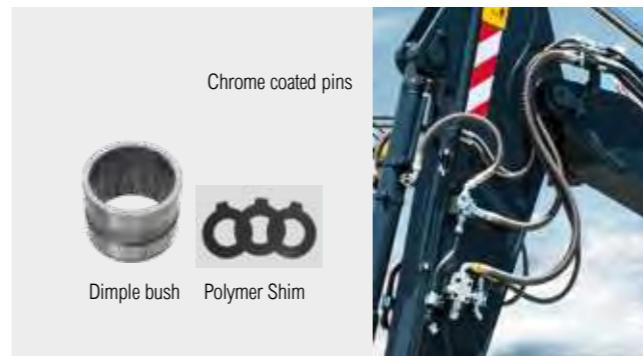

Reinforced upper and lower frame structure

Built for unbeatable strength and sturdiness, the HW140A and HW160A offer solid performance over a long lifetime. The upper and lower frame structures are reinforced for high workload, while the attachments have been rigorously tested for the roughest conditions.



Operator comfort

AIM FOR MORE COMFORT AND CONVENIENCE

...with a spacious cabin and improved ergonomics.

It's easier to be productive when your workplace is comfortable and well designed. That's why we placed operators right at the centre of the HW140A / HW160A cabin design. Light and spacious, it features a high-quality, adjustable seat and an ergonomic layout that places controls within easy, comfortable reach. Numerous features have been added to enhance convenience, reduce fatigue and promote efficiency.

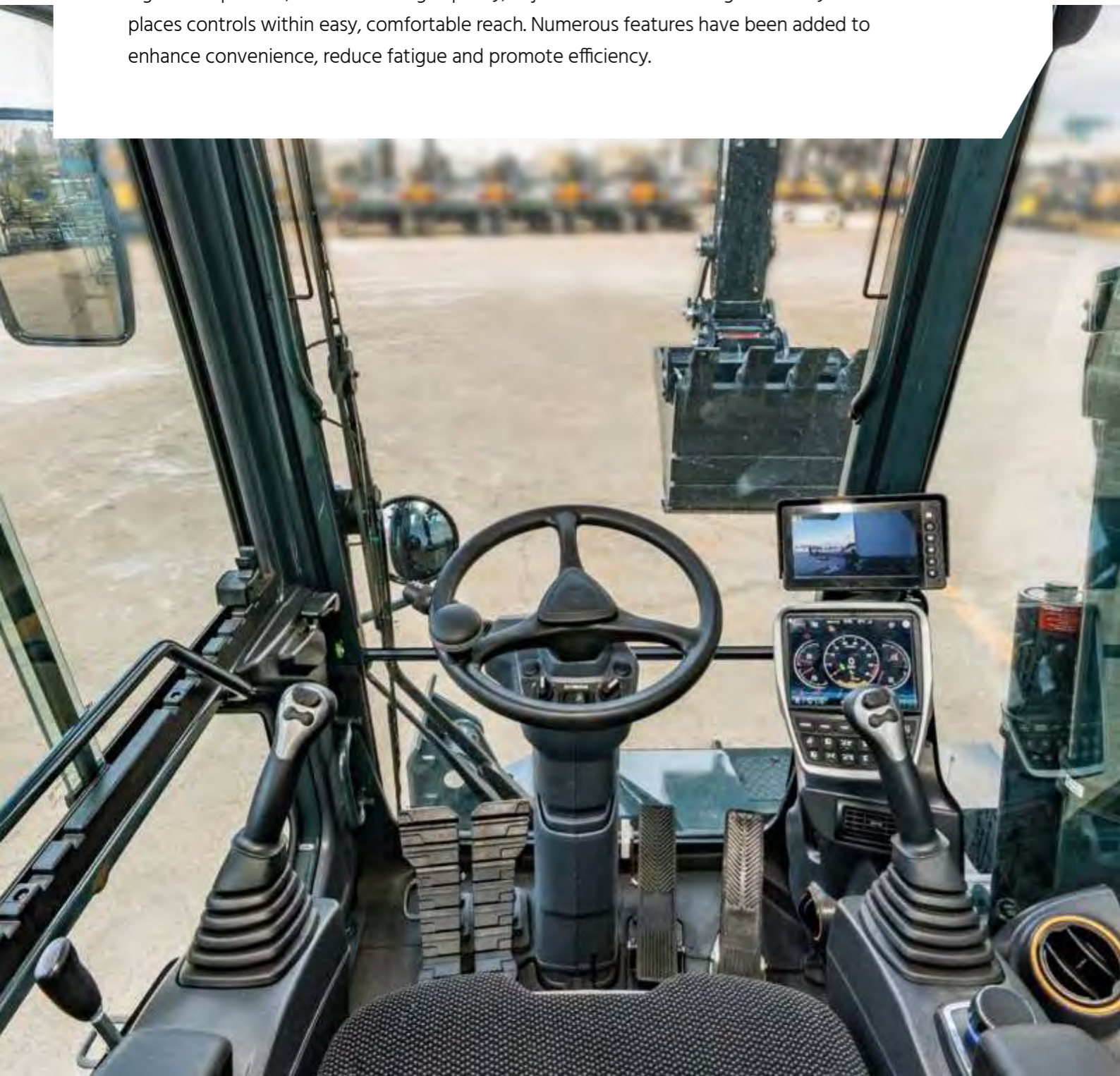

3-way adjustable steering column

The steering column is ergonomically positioned and adjustable so that every operator can work more comfortably and productively.



Deluxe seat

The air suspension seat is ergonomically designed and heated, helping operators to work longer without fatigue in all weathers and seasons.



Work modes

The operator can select from three different work modes – Park, Work and Travel – for convenient automatic control of a range of functions.

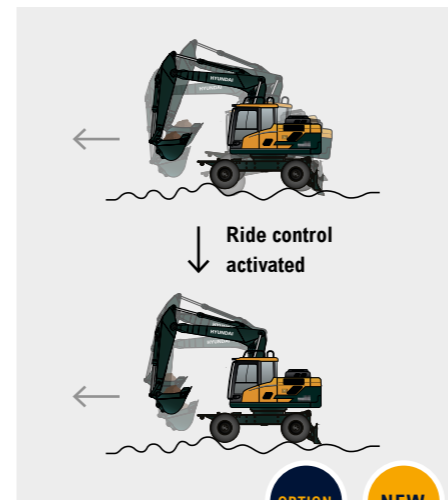

Ride control

A ride control system is available as an option. This reduces rocking of the excavator body, ensuring a smooth ride on all kinds of terrain, and reducing spillage from the bucket.



Attachment flow control

The load sensing hydraulic system allows for superior flow sharing performance, resulting in optimal multi-functional operation with excellent controllability. The machine memory accommodates 20 attachments (10 breaker types and 10 crusher types) to suit a wide range of applications and environments.

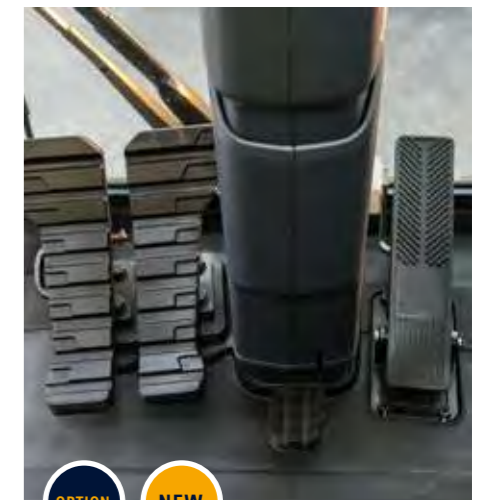

Auxiliary joystick and pedal control

A 2-way proportional auxiliary joystick and pedal control enable effortless operation to minimise operator fatigue.

Wide touchscreen monitor

The 8-inch touchscreen is one of the largest on the market and features WiFi connectivity, allowing operators to take advantage of smart technologies as they work.



Joystick steering

The HW140A and HW160A feature right-hand joystick steering, for quick, easy manoeuvring and enhanced productivity.



FNR and Ram Lock Switch on joystick

In the HW140A/HW160A, the operator finds the Forward/Reverse switch right at his fingertip. The front axle oscillation lock can also be activated from the joystick. A gain in convenience and productivity for demanding jobs.

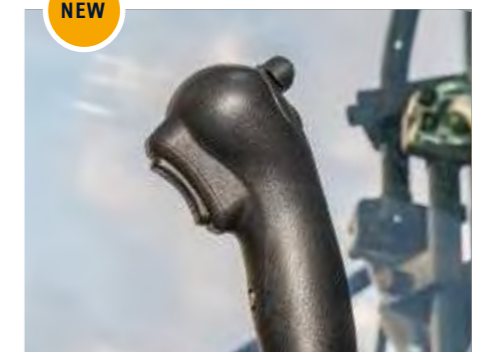

Operator comfort

AIM FOR EASY, EFFICIENT CONTROL

... with the right technologies to assist you.



Floating boom function

The floating boom setting allows the boom to move up and down freely under its own weight. This enables effortless levelling of surfaces.



Power boost function

The power boost function automatically increases relief pressure for that extra push when you need it.



Cruise control & speed limiter, creep speed drive

The HW140A and HW160A are equipped with cruise control and speed limiter systems, allowing operators to relax while maintaining a steady speed over longer distances. When creep speed is activated, the excavator will drive at a maximum speed of 3.5 km/hr. This gives the operator better control and higher torque with minimal effort.



Full climate control

The efficient air conditioning is enhanced with full climate control for fast heating, cooling and defrosting.



Advanced audio system

The audio system includes a radio player, USB-based MP3 player and Bluetooth for hands-free calling. The smart display of the cabin monitor mirrors mobile phone functions, keeping operators entertained and connected all day long.

Jog dial module

For added convenience, an integrated jog dial module allows easy control of the air conditioning and instrument cluster navigation.



Fine swing control

Fine swing control enables smooth movement at the beginning and end of swing operations. This improves precision in a wide range of applications and reduces spillage from the bucket.

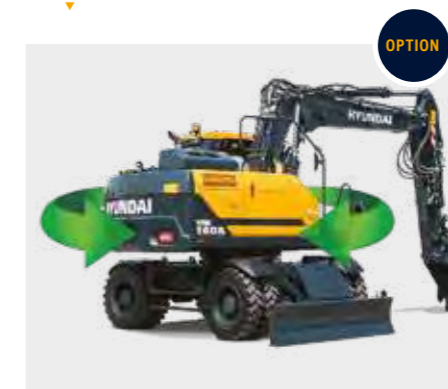

Swing lock system

Swing lock disables the turret swing to increase safety when needed. This is particularly useful during road travel, when working next to roads and railways, or near buildings and other obstacles.

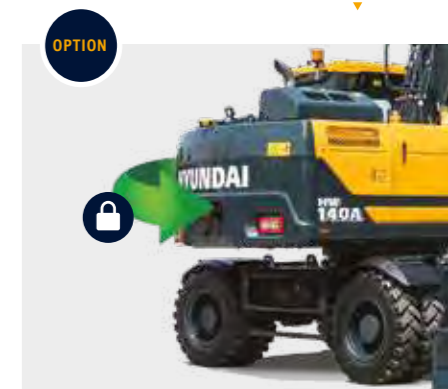

Safety

AIM FOR THE HIGHEST PROTECTION FOR WORKERS

... with zero compromise on efficiency.

The Hyundai approach to safety goes far beyond just meeting regulatory standards. We prioritise safety in every aspect of our machines and work with our customers to keep improving protection for operators, co-workers, passers-by, surrounding buildings and of course the machines themselves. This includes robust, protective machine structures, a cabin design that offers a clear all-round view of machine surroundings and a series of additional features and technologies that increase peace of mind on and off the work site.



◀ **Safety valves on all cylinders**
As a standard feature, safety valves are integrated on the boom, arm, blade and ram lock hydraulic cylinders.

◀ **LED lights**
All the working lights are LED-type for greater visibility during work and travel.

NEW

◀ **Safety glass**
Safety glass has been used for all windows, including a laminated glass front window for added protection

◀ **Cabin suspension mount**
Integrated silencer blocks minimise noise and vibration inside the cabin, reducing fatigue and allowing safer, more enjoyable operation.

◀ **Improved cabin access**
The cabin access steps have been redesigned for safe, convenient entry.

NEW

Safety

Axles and fenders

The HW140A has been equipped with an HD axle for higher durability, while a wide axle is optionally available for the HW160A to enhance stability in different conditions and material handling applications. Sturdy fenders, covering the wheel even when steering, have been added on both HW140A and HW160A to prevent flying debris from the tyres while driving.



OPTION

Auto safety lock

The auto safety lock feature prevents unintentional ignition and random machine movement. When the safety lever is unlocked, the engine cannot be started and the system will not engage, even if the joystick is pressed accidentally.



Emergency steering

If the hydraulic supply should fail, manual steering is automatically enabled.



ROPS / FOPS certified cabin

To protect workers, the cabin structure is reinforced with integrally welded, low-stress, high-strength steel. It is certified to ISO 12117-2 (ROPS - Roll-over Protective Structures) and ISO 10262 Level 2 (FOPS - Falling Object Protective Structures) safety standards.



OPTION

Advanced Around View Monitoring (AAVM)

Hyundai's AAVM camera system can be installed as an option, giving operators a 360° overview of their immediate working environment, including rear, side mirror and birds-eye views. It also integrates Intelligent Moving Object Detection (IMOD) technology that senses and warns the driver when people or objects come within five metres of the machine.



NEW

OPTION

Radar with second monitor

The radar system detects static or moving objects within a 10-metre radius of the rear of the excavator, day or night. Obstacles are displayed on a separate monitor giving operators maximum visibility.

Seatbelt warning alarm

Operators are reminded to fasten their seat belt by an audible and visible alarm.



New upper structure design

The upper structure has been redesigned to improve access for maintenance.



NEW

Serviceability & Connectivity

AIM FOR MAXIMUM UPTIME AND EFFICIENT SERVICING

... with intelligent machine management and easy access.

Our A-Series wheeled excavators are designed with quick, low-effort servicing in mind. Every component and material has been optimised to ensure a long, trouble-free life. Hyundai's innovative Hi MATE telematics system enables full monitoring of machine activity and performance. Maximum connectivity is integrated to help owners create a smart construction site and protect profitability as their business grows.



OPTION

Fuel filler pump
An integrated fuel filler pump with auto stop makes refuelling quick and easy.



Mobile Fleet app
Hyundai's new Mobile Fleet app provides all the information you need to run your fleet efficiently and economically. Based on telematics, this advanced solution uses simple graphics and key performance data for smart fleet management.

DEF/AdBlue filler access
Access to the DEF/AdBlue tank filling point has been made easier with redesigned steps.



HiMATE

Boost efficiency and performance

For maximum convenience and security, the HW140A and HW160A feature Hyundai's exclusive Hi MATE remote fleet management system, which uses mobile data technology to provide the highest level of service and support. You can monitor your equipment wherever you are via a dedicated website or mobile app, with access to working parameters like total engine hours, machine utilisation, actual performed working hours, fuel consumption and machine location.



ECD (Engine Connected Diagnostics)
ECD provides troubleshooting advice as well as tailored servicing and parts support from Cummins Quick Serve. Service technicians are supported with remote diagnostics reports allowing them to prepare for initial site visits, bring the right tools and achieve a higher problem resolution rate.



We're all connected!

NEW



Just 5 minutes

from fault occurrence to report



One-stop solution



Increase productivity

By providing information such as service hours, idle time and fuel consumption, Hi MATE saves you money and improves productivity. Service alerts enable better maintenance planning.



Monitor your machines

Hi MATE's real-time location information allows better, more convenient monitoring of your equipment. Just log onto the Hi MATE website or mobile app to see your machines at any time, from any location. Receive data online, by e-mail or directly on your mobile device.



Improve security

Protect your equipment from theft or unauthorised usage. Hi MATE's geofencing alerts notify you automatically when a machine leaves a predetermined zone.

Parts & Warranties

HYUNDAI GENUINE PARTS AND WARRANTIES: THE BEST WAY TO PROTECT YOUR INVESTMENT

Hyundai Genuine Parts, accessories and warranty programmes are specially designed to keep your machine covered. They increase uptime and maintain the performance, comfort, and convenience that are built into your equipment.



A network you can rely on

Hyundai Construction Equipment Europe prioritises quick, reliable intervention to keep your equipment running reliably. In its 13000 m² warehouse, Hyundai covers over 96% of all Genuine Parts. With one of Europe's most advanced automated warehousing systems, we are able to maintain availability and efficient delivery of all our Genuine Parts. Moreover, we guarantee a 24-hour delivery service across our European dealer network.



Fuel filters

Hyundai fuel filters provide the right degree of filtration to keep your engine clean. They are designed to meet and exceed the engine manufacturer's prerequisites for water separation and dirt filtration, prolonging the life of your engine.



Hyundai Genuine Parts

Hyundai Genuine Parts have the same design as those installed when your machine left the factory. They are subjected to rigorous quality inspections and tests to make sure they meet Hyundai's strict requirements for quality and durability. As well as minimising downtime, this helps to ensure peak performance on every task.



Aftermarket kits

You can order Hyundai aftermarket kits via your dealer. This AAVM system for example, improves safety in and around your work environment at all times.



Hyundai warranties

Our warranties are designed to give you the cover you need to build your business with confidence and peace of mind.

Standard warranties

We offer standard warranty coverage for all wheeled excavators. In addition, optional and extended warranty periods are available, so you can benefit from full warranty coverage for longer, and even over the full lifetime of the machine. Please discuss the optimal solution for your needs with your local Hyundai dealer.

Extended warranties

Our extended warranties help you maintain full control over your operating costs. If you combine an extended warranty programme with a tailored maintenance contract, you can completely avoid unexpected costs.

Take the tour!

HW140A / HW160A

Productivity & Efficiency

- High-performing Stage V engine with advanced exhaust aftertreatment **NEW**
- Load sensing hydraulic system **NEW**
- Variable Power Control **NEW**
- Hydrostatic 4-wheel drive
- Eco gauge
- Trailer hitch preparation **NEW** **OPTION**
- Electronically controlled reversible fan **NEW**
- Tiltrotator **NEW** **OPTION**
- 2D and 3D grading **NEW** **OPTION**

Comfort

- 3-way adjustable steering column **NEW**
- Largest touchscreen monitor on the market (incl. WiFi)
- Attachment flow control
- Joystick steering **OPTION**
- FNR and Ram Lock Switch on Joystick **NEW**
- Ride control **NEW** **OPTION**
- Cruise control & speed limiter
- Advanced audio system
- Full climate control



Safety

- Advanced Around View Monitoring (AAVM) camera system **OPTION**
- Radar with second monitor **NEW** **OPTION**
- LED working lights
- ROPS / FOPS certified cabin
- Safety glass
- Wide axle (HW160A) and fenders **OPTION**
- Auto safety lock **NEW**
- Safety valves on all cylinders
- Automatic digging brake **NEW** **OPTION**

Serviceability & Connectivity

- ECD (Engine Connected Diagnostics) **NEW**
- Improved DEF/AdBlue filler access
- Fuel filler pump with auto stop **OPTION**
- Hyundai Hi MATE telematics system
- Mobile Fleet app **OPTION**

Durability

- Reinforced upper and lower frame structure
- Reinforced pins, bushings and polymer shims
- Durable cooling module
- Hi-grade (high-pressure) hoses
- Centralised greasing system **OPTION**

HW140A / HW160A SPECIFICATIONS

SPECIFICATIONS	HW140A	HW160A
ENGINE		
Maker / Model	CUMMINS / B4.5	
Type	4 cylinder, water cooled, 4-cycle, turbocharged charge air cooled, direct injection, electronic controlled diesel engine.	
Gross Power	129 kW (173 hp) at 2200 rpm	
Net Power	127 kW (170 hp) at 2200 rpm	
Max. Power	129 kW (173 hp) at 2200 rpm	
Peak Torque	780 N m at 1500 rpm	
Displacement	4.5 l	
HYDRAULIC SYSTEM		
Advanced Load Sensing System (LUDV)		
Load independent flow sharing		
MAIN PUMP		
Type	Variable displacement pump	
Max. Flow	232 lpm @ 1600 rpm	261 lpm @ 1800 rpm
AUX PUMP for steering or rotation piping		
Type	piston pumps	
Max. Flow	50 lpm @ 1600 rpm	
HYDRAULIC MOTORS		
Travel	Bent - axis pistons motor with brake valve and parking brake	
Swing	Radial Piston Motor	
RELIEF VALVE SETTING		
Implement Circuits	350 kgf/cm ² (4970 psi)	
Travel	380 kgf/cm ² (5400 psi)	
Power Boost (boom, arm, bucket)	380 kgf/cm ² (5400 psi)	
Swing Circuit	285 kgf/cm ² (4050 psi)	
Pilot Circuit	40 kgf/cm ² (570 psi)	35 kgf/cm ² (500 psi)
Service Valve	Installed	
HYDRAULIC CYLINDERS		
No. of cylinder bore X stroke	Boom: 2-105 x 1105 mm	Boom: 2-110 x 1090 mm
	Arm: 1-115 x 1138 mm	Arm: 1-120 x 1235 mm
	Bucket: 1-100 x 850 mm	Bucket: 1-105 x 995 mm
	Blade: 2-100 x 241 mm	Blade: 2-110 x 235 mm
	Outrigger: 2-110 x 446 mm	Outrigger: 2-125 x 463 mm
		2-PCS boom: 2-105 x 992 mm
	Adjust(boom): 1-145 x 634 mm	Adjust(boom): 1-160 x 613 mm
* Hyundai Bio Hydraulic Oil (HBHO) available		
DRIVES & BRAKES		
4-wheel hydrostatic drive. Constant mesh, helical gear transmission provides 2 forward and reverse travel speeds.		
Max. drawbar pull	10720 kgf	
Travel speed	1st	9.5 km/h
	2nd	37 km/h or 20 km/h (Option)
Gradeability	35° (70 %)	
Service Brake:		
* Independent dual brake, front and rear axle full hydraulic power brake.		
* Spring released and hydraulic applied wet type multiple disc brake.		
Parking Brake:		
* Spring applied and hydraulic released wet disc brake type in transmission.		
CONTROLS		
Pilot pressure operated, proportional joysticks, steering wheel and foot pedals for effortless operation.		
Pilot Control	Two joysticks with one safety lever	
	(LH) : Swing and arm, (RH) : Boom and bucket (ISO)	
FNR switch on RH joystick / Ram lock switch on LH joystick		
Attachment Control	3 modes available: Push / Proportional / Permanent	
Engine Throttle	Electric, Dial type	
Operation Mode	3 modes available: P-Parking W-Working T-Travel	

SPECIFICATIONS	HW140A	HW160A		
AXLE & WHEEL				
Full floating front axle is supported by center pin for oscillation. Oscillation lock (ram lock) function for safe operation.				
Rear axle is fixed on the lower chassis.				
Front axle oscillation angle	TBA			
Tyres	10.00-20-14PR, Dual (tube type)			
(Optional)	10.00-20, Dual (solid type)	10.00-20, Dual (solid type)		
		10.00-20-16PR, Dual (tube type)		
STEERING SYSTEM				
Hydraulically actuated, orbitrol type steering system actuates on front wheels through steering cylinders.				
Min. turning radius	6300 mm			
SWING SYSTEM				
Swing motor	Fixed displacement axial piston motor			
Swing reduction	Planetary gear reduction			
Swing bearing lubrication	Grease-bathed			
Swing brake	Multi wet disc			
Swing speed	9.5 rpm	9.3rpm		
COOLANT & LUBRICANT CAPACITY				
		liter		
Fuel tank	250			
Engine coolant	19.5			
Engine oil	11.0			
Swing device - gear oil (OPT)	6.2 (5.0)			
Swing device - grease (OPT)	(1.2)			
Axle	Front	15.5		
	Rear	17.5		
Transmission	2.5			
Hydraulic system (including tank)	204			
Hydraulic tank	122			
DEF/AdBlue®	27			
UNDERCARRIAGE				
Reinforced box-section frame is all-welded, low-stress. Dozer blade and outrigger options are available. Easily replaceable through bolt-on design.				
Dozer blade	Parallelogram-mounted dozer blade to support machine when working, also for leveling and back filling.			
Outriggers	Indicated for max. operation stability when digging and lifting. Can be mounted on front/or rear.			
OPERATING WEIGHT (APPROXIMATE)				
	Operating weight, including 4600 mm, mono boom / 4710 mm 2pc boom, 2450 mm arm, SAE heaped 0.58 m ³ bucket, lubricant, coolant, full fuel tank, hydraulic tank and standard equipment.	Operating weight, including 5000 mm mono boom / 5100 mm 2pc boom, 2200 mm arm, SAE heaped 0.70 m ³ bucket, lubricant, coolant, full fuel tank, hydraulic tank and standard equipment.		
OPERATING WEIGHT	Mono boom (kg)	2-pc boom (kg)	Mono boom (kg)	2-pc boom (kg)
Rear dozer blade	14900	15860	17580	18390
Rear outriggers	15120	16080	17850	18660
Front outriggers and rear blade	15900	16860	18800	19610
Front blade and rear outriggers	15830	16790	18800	19610
Four outriggers	16120	17080	19070	19880
AIR CONDITIONING SYSTEM				
The air conditioning system contains fluorinated greenhouse gas refrigerant R134a (Global Warming Potential = 1430). The system contains 0.75 kg of refrigerant representing a CO ₂ equivalent of 1.07 metric tonnes. For more information, please refer to the manual.				

HW140A DIMENSIONS & WORKING RANGE

HW140A MONO BOOM DIMENSIONS

4.6 m Mono boom, 2.0 m, 2.45 m, 2.6 m, 3.1 m Arm, Rear dozer

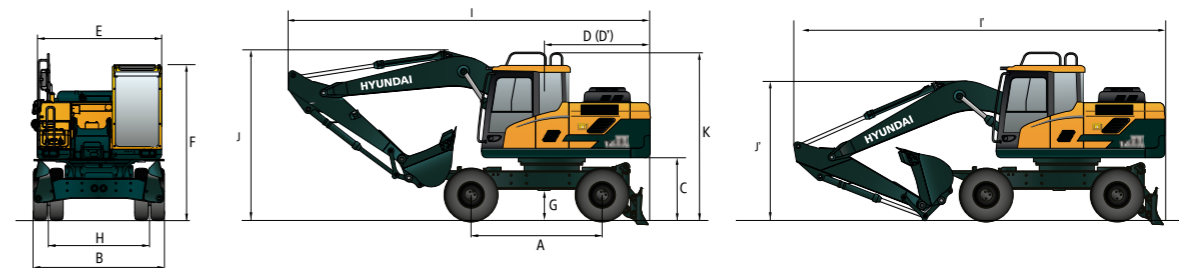

A	Wheel base	2600
B	Overall width (STD)	2500
C	Ground clearance of counterweight	1260
D	Rear-end distance	2150
D'	Rear-end swing radius	2150
E	Upperstructure width	2485
F	Overall height of cab	3190
G	Min. ground clearance	390
H	Tread	1914
K	Overall height of guardrail	3423

	Arm Length	2000	2450	2600	3100
I	Overall length (Traveling position)	7665	7485	7400	7080
I'	Overall length (Shipping position)	7600	7660	7670	7590
J	Overall height of boom (Traveling position)	3250	3640	3760	4430
J'	Overall height of boom (Shipping position)	2720	2930	3050	3420

HW140A MONO BOOM WORKING RANGE

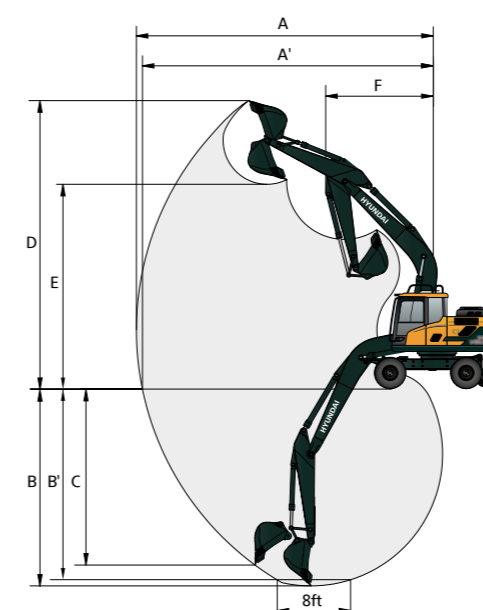

Unit : mm

Boom Length	4600				
Arm Length	2000	2450	2600	3100	
A	Max. Digging Reach	7880	8310	8450	8910
A'	Max. Digging Reach on Ground	7640	8090	8230	8705
B	Max. Digging Depth	4670	5120	5270	5770
B'	Max. Digging Depth (8' Level)	4410	4910	5070	5590
C	Max. Vertical Wall Digging Depth	4215	4670	4810	5320
D	Max. Digging Height	8530	8840	8930	9200
E	Max. Dumping Height	6090	6390	6480	6750
F	Min. Swing Radius	2680	2680	2690	2720

HW140A DIMENSIONS & WORKING RANGE

HW140A 2-PIECE BOOM DIMENSIONS

4.71 m 2-Piece boom, 2.0 m, 2.45 m, 2.6 m Arm, Rear dozer

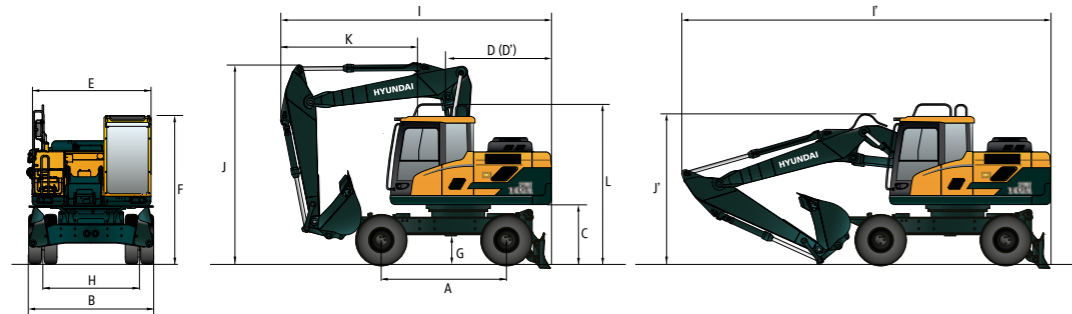

A	Wheel base	2600
B	Overall width (STD)	2500
C	Ground clearance of counterweight	1260
D	Rear-end distance	2150
D'	Rear-end swing radius	2150
E	Upperstructure width	2485
F	Overall height of cab	3190
G	Min. ground clearance	390
H	Tread	1914
K	Overall height of guardrail	3423

Boom Length		4710		
Arm Length		2000	2450	2600
I	Overall length (Traveling position)	6110	5760	6520
I'	Overall length (Shipping position)	7795	7800	7810
J	Overall height of boom (Traveling position)	4000	4000	4000
J'	Overall height of boom (Shipping position)	2720	2770	2810
K	End of attachment to steering wheel	2640	2900	3360

HW140A 2-PIECE BOOM WORKING RANGE

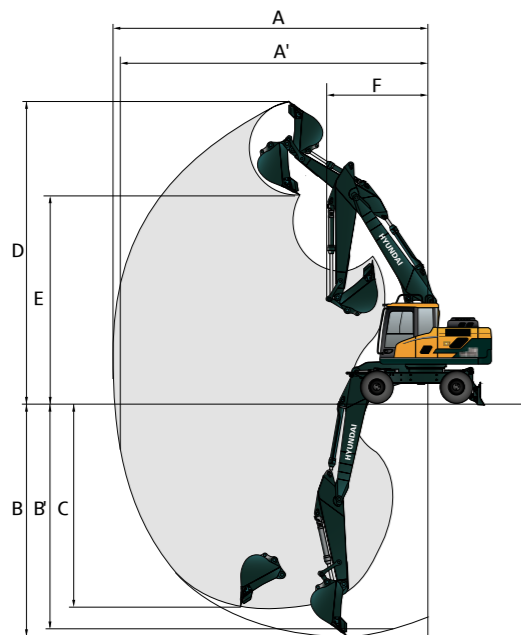

Unit : mm

Boom Length		4710		
Arm Length		2000	2450	2600
A	Max. Digging Reach	8075	8510	8660
A'	Max. Digging Reach on Ground	7850	8300	8450
B	Max. Digging Depth	4650	5100	5250
B'	Max. Digging Depth (8° Level)	4530	4985	5140
C	Max. Vertical Wall Digging Depth	4020	4505	4650
D	Max. Digging Height	9090	9440	9550
E	Max. Dumping Height	6610	6950	7060
F	Min. Swing Radius	2615	2600	2635

HW140A LIFTING CAPACITY

Rating over-front Rating over-side or 360 degrees

HW140A MONO BOOM

4.60 m Mono boom, 2.00 m arm, 1700 kg counterweight equipped and dozer blade down.

Lift-point height m		Lift-point radius								At max. Reach			
		1.5 m		3.0 m		4.5 m		6.0 m		Capacity	Reach		
										kg	m		
6.0 m	kg					*4420	3670			*3330	2910	5.15	
4.5 m	kg					*4790	3570	3560	2240	*3110	2190	6.08	
3.0 m	kg					5500	3350	3490	2180	3050	1900	6.53	
1.5 m	kg					5250	3140	3400	2090	2940	1810	6.62	
0.0 m	kg					*6510	5520	5120	3020	3340	3090	1890	6.34
-1.5 m	kg	*6490	*6490	*9460	5580	5120	3020			3650	2230	5.66	
-3.0 m	kg			*6990	5760					*4600	3300	4.37	

4.60 m Mono boom, 2.45 m arm, 1700 kg counterweight equipped and dozer blade down.

Lift-point height m		Lift-point radius								At max. Reach				
		1.5 m		3.0 m		4.5 m		6.0 m		Capacity	Reach			
										kg	m			
7.5 m	kg									*2890	*2890	4.16		
6.0 m	kg					*3880	3740			*2390	*2390	5.70		
4.5 m	kg					*4330	3620	3590	2270	*2250	1940	6.55		
3.0 m	kg					*7850	6310	*5330	3390	3500	2180	*2260	1700	6.97
1.5 m	kg					*5690	5650	5270	3150	3390	2080	*2410	1630	7.05
0.0 m	kg					*6760	5460	5100	3000	3310	2010	*2740	1690	6.79
-1.5 m	kg	*5600	*5600	*9980	5480	5060	2960	3300	2000	3190	1940	6.16		
-3.0 m	kg			*7990	5620	5160	3050			4400	2650	5.01		
-4.5 m	kg													

4.60 m Mono boom, 2.60 m arm, 1700 kg counterweight equipped and dozer blade down.

Lift-point height m		Lift-point radius								At max. Reach								
		1.5 m		3.0 m		4.5 m		6.0 m		Capacity	Reach							
										kg	m							
7.5 m	kg									*2660	*2660	4.40						
6.0 m	kg									*2230	*2230	5.87						
4.5 m	kg									*2100	1870	6.70						
3.0 m	kg									*4180	3650	3610	2280	*2110	1650	7.12		
1.5 m	kg									*7510	6380	*5190	3410	3510	2190	*2110	1650	7.12
0.0 m	kg									*6430	5680	5280	3150	3390	2080	*2250	1580	7.19
-1.5 m	kg									*6820	5440	5090	2990	3300	2000	*2540	1630	6.94
-3.0 m	kg	*5360	*5360	*10110	5440	5040	2950	3290	1990	3060	1860	6.33						
-4.5 m	kg	*9520	*9520	*8270	5580	5120	3020			4130	2490	5.21						

4.60 m Mono boom, 3.10 m arm, 1700 kg counterweight equipped and dozer blade down.

Lift-point height m		Lift-point radius										At max. Reach													
		1.5 m		3.0 m		4.5 m		6.0 m		7.5 m		Capacity	Reach												
												kg	m												
7.5 m	kg													*2150	*2150	5.13									
6.0 m	kg													*1860	*1860	6.43									
4.5 m	kg													*3310	2310	*1770	1660	7.20							
3.0 m	kg													*6350	*6350	*4690	3470	3530	2210	*2090	1510	*1790	1480	7.58	
1.5 m	kg													*9370	5840	5330	3190	3400	2080	2400	1460	*1900	1410	7.65	
0.0 m	kg													*7170	5460	5100	2990	3290	1980			*2120	1450	7.42	
-1.5 m	kg	*4710	*4710	*9570	5380	5010	2910	3240	1940					*2570	1620	6.85									
-3.0 m	kg	*7920	*7920	*9090	5470	5040	2940							3430	2070	5.84									
-4.5 m	kg																								

- Lifting capacity are based on ISO 10567.
- Lifting capacity of the HW A-series does not exceed 75% of tipping load with the machine on firm, level ground or 87% of full hydraulic capacity.
- The Lift-point is bucket pivot mounting pin on the arm (without bucket mass).
- (*) indicates load limited by hydraulic capacity.
- Caution: please be aware of the local regulations and instructions for lifting operations.

HW140A LIFTING CAPACITY

Rating over-front Rating over-side or 360 degrees

HW140A 2-PIECE BOOM

4.71 m 2-Piece boom, 2.00 m arm, 2200 kg counterweight equipped and dozer blade down.

Lift-point height m		Lift-point radius						At max. Reach		
		1.5 m		3.0 m		4.5 m		Capacity		Reach m
7.5 m	kg							*4410	*4410	3.69
6.0 m	kg			*4210	4020			*3470	2970	5.37
4.5 m	kg	*5800	*5800	*4630	3890	3870	2460	*3200	2280	6.26
3.0 m	kg			*5580	3650	3780	2390	3170	2000	6.71
1.5 m	kg			5670	3420	3680	2300	3070	1920	6.79
0.0 m	kg	*4830	*4830	5540	3310	3620	2240	3220	2010	6.52
-1.5 m	kg	*9500	6110	5540	3310			3780	2340	5.86
-3.0 m	kg									

4.71 m 2-Piece boom, 2.45 m arm, 2200 kg counterweight equipped and dozer blade down.

Lift-point height m		Lift-point radius						At max. Reach		
		3.0 m		4.5 m		6.0 m		Capacity		Reach m
7.5 m	kg							*3030	*3030	4.46
6.0 m	kg			*3710	*3710			*2500	*2500	5.92
4.5 m	kg			*4190	3950	*3880	2490	*2320	2030	6.74
3.0 m	kg			*5190	3690	3800	2400	*2300	1800	7.15
1.5 m	kg			5690	3440	3670	2280	*2410	1730	7.23
0.0 m	kg	*5270	*5270	5520	3290	3590	2210	*2670	1800	6.98
-1.5 m	kg	*9410	6000	5480	3250	3580	2200	*3220	2050	6.37
-3.0 m	kg									

4.71 m 2-Piece boom, 2.60 m arm, 2200 kg counterweight equipped and dozer blade down.

Lift-point height m		Lift-point radius										At max. Reach		
		1.5 m		3.0 m		4.5 m		6.0 m		7.5 m		Capacity		Reach m
7.5 m	kg					*3340	*3340			*2790	*2790	4.70		
6.0 m	kg			*3560	*3560	*2730	2520	*2330	*2330	6.10				
4.5 m	kg			*4050	3980	*3770	2510	*2170	1960	6.90				
3.0 m	kg			*7450	6900	*5050	3710	3810	2400	*2150	1750	7.30		
1.5 m	kg					5700	3440	3680	2290	*2250	1680	7.37		
0.0 m	kg			*5350	*5350	5510	3280	3580	2200	*2480	1740	7.13		
-1.5 m	kg			*9050	5960	5460	3240	3570	2190	*2970	1970	6.53		
-3.0 m	kg					5550	3310							

- Lifting capacity are based on ISO 10567.
- Lifting capacity of the HW A-series does not exceed 75% of tipping load with the machine on firm, level ground or 87% of full hydraulic capacity.
- The Lift-point is bucket pivot mounting pin on the arm (without bucket mass).
- (*) indicates load limited by hydraulic capacity.
- Caution: please be aware of the local regulations and instructions for lifting operations.

HW140A BUCKET SELECTION GUIDE & DIGGING FORCE

BUCKETS



SAE heaped m³	0.50	0.61	0.52	0.65	0.71	□ 0.45	● 0.55
			0.58				

HW140A, 1700 kg counterweight equipped, dozer blade up.

Capacity m³	Width mm	Weight kg	Tooth EA	Recommendation mm			
				4600 Mono Boom			
				2000 Arm	2450 Arm	2600 Arm	3100 Arm
0.58	950	480	5	○	■	▲	▲
0.52	870	460	5	○	■	■	▲
0.65	1060	513	5	■	▲	▲	×
0.71	1140	536	5	▲	▲	×	×
0.45	1520	410	0	●	●	○	■
0.55	1800	585	0	○	■	▲	▲
0.50	762	439	4	●	○	■	■
0.61	914	490	5	■	▲	▲	▲

HW140A, 2200 kg counterweight equipped, dozer blade up.

Capacity m³	Width mm	Weight kg	Tooth EA	Recommendation mm						
				4600 Mono Boom			4710 2-Piece Boom			
				2000 Arm	2450 Arm	2600 Arm	3100 Arm	2000 Arm	2450 Arm	2600 Arm
0.58	950	480	5	○	○	■	▲	○	■	■
0.52	870	460	5	●	○	○	■	●	○	○
0.65	1060	513	5	○	■	■	▲	■	▲	▲
0.71	1140	536	5	■	▲	▲	×	■	▲	▲
0.45	1520	410	0	●	●	●	○	●	●	●
0.55	1800	585	0	○	■	■	▲	○	■	■
0.50	762	439	4	●	●	○	■	●	○	○
0.61	914	490	5	○	■	■	▲	○	■	■

- Applicable for materials with density of 2100 kg/m³ or less
- Applicable for materials with density of 1800 kg/m³ or less
- Applicable for materials with density of 1500 kg/m³ or less
- ▲ Applicable for materials with density of 1200 kg/m³ or less
- ×

ATTACHMENT

Booms and arms are welded with a low-stress, full-box section design. 2.0 m / 2.45 m / 2.6 m / 3.1 m arms are available.

DIGGING FORCE

Boom	Length	mm	4600 Mono				4710 2-Piece			Remarks:	
			2000	2450	2600	3100	2000	2450	2600		
Bucket digging force	SAE	kN	87.9 [95.4]	87.9 [95.4]	87.9 [95.4]	87.9 [95.4]	87.9 [95.4]	87.9 [95.4]	87.9 [95.4]	:] Power Boost	
		kgf	8956 [9724]	8960 [9729]	8960 [9729]	8956 [9724]	8956 [9724]	8960 [9729]	8960 [9729]		
	ISO	kN	102.9 [111.7]	102.9 [111.8]	102.9 [111.8]	102.9 [111.7]	102.9 [111.7]	102.9 [111.8]	102.9 [111.8]		
		kgf	10489 [11388]	10494 [11393]	10494 [11393]	10488 [11387]	10489 [11388]	10494 [11393]	10494 [11393]		
	Arm crowd force	SAE	kN	74.3 [80.6]	63.6 [69.1]	61.1 [66.4]	54.7 [59.4]	74.3 [80.6]	63.6 [69.1]		61.1 [66.4]
			kgf	7569 [8218]	6485 [7041]	6230 [6764]	5578 [6057]	7569 [8218]	6485 [7041]		6230 [6764]
ISO		kN	77.9 [84.6]	66.4 [72.0]	63.6 [69.1]	56.7 [61.6]	77.9 [84.6]	66.4 [72.0]	63.6 [69.1]		
		kgf	7942 [8622]	6763 [7343]	6485 [7041]	5781 [6277]	7942 [8622]	6763 [7343]	6485 [7041]		

Note : Arm weight includes bucket cylinder, linkage, and pin

HW160A DIMENSIONS & WORKING RANGE

HW160A MONO BOOM DIMENSIONS

5.0 m Mono boom, 2.0 m, 2.45 m, 2.6 m, 3.1 m Arm, Rear dozer

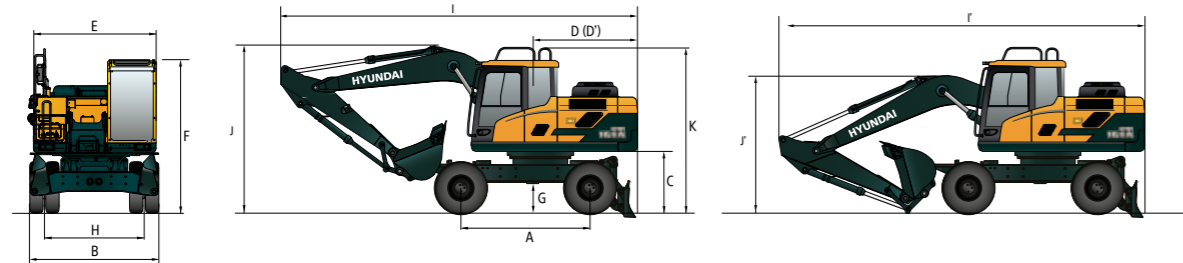

A	Wheel base	2600
B	Overall width (STD)	2530
C	Ground clearance of counterweight	1265
D	Rear-end distance	2240
D'	Rear-end swing radius	2240
E	Upperstructure width	2485
F	Overall height of cab	3190
G	Min. ground clearance	370
H	Tread	1914
K	Overall height of guardrail	2530

	Arm Length	2000	2450	2600	3100
I	Overall length (Traveling position)	7970	7940	7960	7990
I'	Overall length (Shipping position)	8280	8215	8240	8210
J	Overall height of boom (Traveling position)	4000	3810	3900	4000
J'	Overall height of boom (Shipping position)	3095	2970	3250	3530

HW160A DIMENSIONS & WORKING RANGE

HW160A 2-PIECE BOOM DIMENSIONS

5.1 m 2-Piece boom, 2.0 m, 2.45 m, 2.6 m Arm, Rear dozer

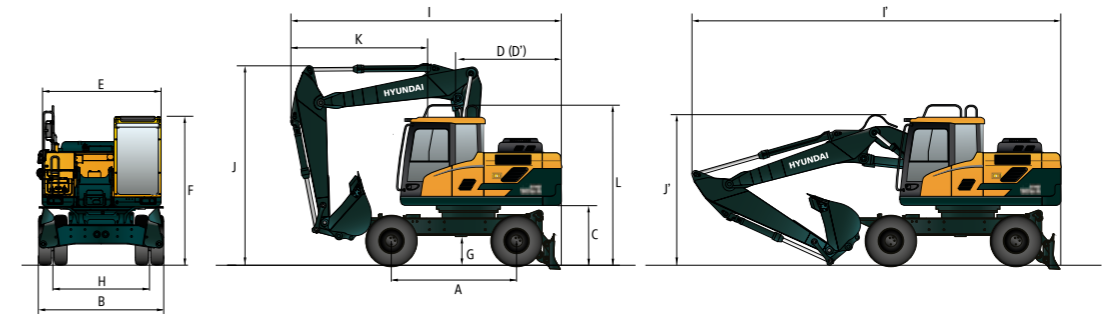

A	Wheel base	2600
B	Overall width (STD)	2530
C	Ground clearance of counterweight	1265
D	Rear-end distance	2240
D'	Rear-end swing radius	2240
E	Upperstructure width	2485
F	Overall height of cab	3190
G	Min. ground clearance	370
H	Tread	1914
K	Overall height of guardrail	2530

	Boom Length	5100		
	Arm Length	2000	2450	2600
I	Overall length (Traveling position)	6715	6250	6205
I'	Overall length (Shipping position)	8390	8345	8320
J	Overall height of boom (Traveling position)	4000	3990	3990
J'	Overall height of boom (Shipping position)	2990	2950	3165
K	End of attachment to steering wheel	3470	3010	2960

HW160A MONO BOOM WORKING RANGE

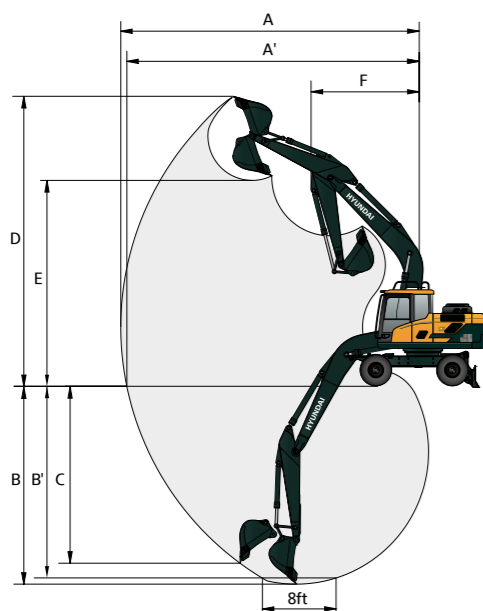

Unit : mm

Boom Length	5000				
Arm Length	2000	2450	2600	3100	
A	Max. Digging Reach	8360	8820	8865	9285
A'	Max. Digging Reach on Ground	8140	8610	8660	9090
B	Max. Digging Depth	5160	5610	5760	6260
B'	Max. Digging Depth (8' Level)	4900	5400	5530	6040
C	Max. Vertical Wall Digging Depth	4430	5060	4870	5210
D	Max. Digging Height	8650	9010	8810	8925
E	Max. Dumping Height	6030	6360	6220	6350
F	Min. Swing Radius	3480	3170	3450	3500

HW160A 2-PIECE BOOM WORKING RANGE

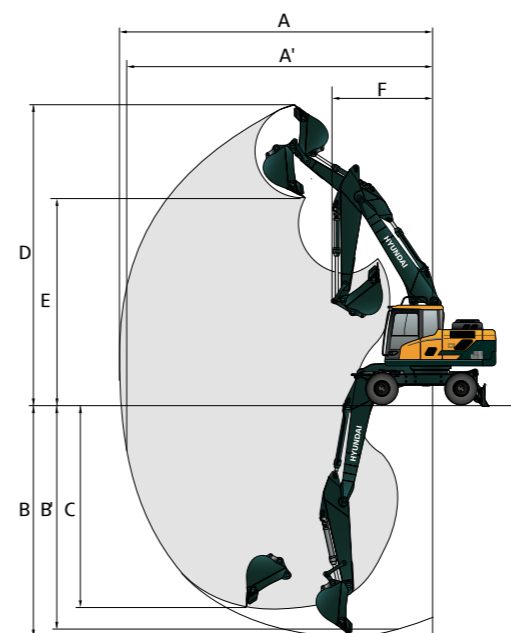

Unit : mm

Boom Length	5100			
Arm Length	2000	2450	2600	
A	Max. Digging Reach	8560	9020	9090
A'	Max. Digging Reach on Ground	8350	8820	8890
B	Max. Digging Depth	5170	5630	5750
B'	Max. Digging Depth (8' Level)	5060	5520	5650
C	Max. Vertical Wall Digging Depth	4325	4860	4860
D	Max. Digging Height	9435	9845	9730
E	Max. Dumping Height	6730	7130	7040
F	Min. Swing Radius	3390	3040	3505

HW160A LIFTING CAPACITY

Rating over-front Rating over-side or 360 degrees

HW160A MONO BOOM

5.00 m Mono boom, 2.00 m arm, 2910 kg counterweight equipped and dozer blade down.

Lift-point height m		Lift-point radius								At max. Reach		
		1.5 m		3.0 m		4.5 m		6.0 m		Capacity	Reach	
												m
6.0 m	kg					*4560	*4560			*4580	3240	5.60
4.5 m	kg					*5180	4470	4430	2860	3920	2530	6.47
3.0 m	kg					*6290	4170	4320	2760	3480	2230	6.90
1.5 m	kg					6430	3920	4190	2640	3360	2130	6.99
0.0 m	kg					6290	3800	4120	2580	3510	2210	6.73
-1.5 m	kg		*9960	7040	6290	3800	4130	2590	4040	2540		6.10
-3.0 m	kg		*7850	7220	*5540	3920			*4790	3470		4.94

5.00 m Mono boom, 2.45 m arm, 2910 kg counterweight equipped and dozer blade down.

Lift-point height m		Lift-point radius										At max. Reach		
		1.5 m		3.0 m		4.5 m		6.0 m		7.5 m		Capacity	Reach	
														m
7.0 m	kg											*3180	*3180	4.77
6.0 m	kg							*3550	2940			*2750	*2750	6.16
4.5 m	kg					*4730	4540	*4240	2900			*2630	2260	6.96
3.0 m	kg					*5890	4240	4350	2780			*2660	2020	7.36
1.5 m	kg					6470	3960	4200	2650			*2830	1940	7.44
0.0 m	kg			*5870	*5870	6290	3800	4110	2570			3170	2000	7.21
-1.5 m	kg	*5810	*5810	*10160	6950	6250	3770	4090	2550			3570	2250	6.62
-3.0 m	kg	*10280	*10280	*8790	7110	*6160	3840					*4540	2900	5.57
-4.5 m	kg													

5.00 m Mono boom, 2.60 m arm, 2910 kg counterweight equipped and dozer blade down.

Lift-point height m		Lift-point radius										At max. Reach		
		1.5 m		3.0 m		4.5 m		6.0 m		7.5 m		Capacity	Reach	
														m
7.5 m	kg											*3360	*3360	4.96
7.0 m	kg							*3960	2940			*2950	2680	6.31
6.0 m	kg					*4540	4540	*4110	2890			*2830	2180	7.09
4.5 m	kg					*5700	4230	4330	2760			*2880	1940	7.49
3.0 m	kg					6450	3930	4180	2630	3000	1890	2960	1860	7.56
1.5 m	kg			*5970	*5970	6250	3760	4070	2530			3060	1920	7.33
0.0 m	kg	*5590	*5590	*9940	6860	6200	3710	4040	2500			3430	2140	6.76
-1.5 m	kg	*9860	*9860	*9010	7010	*6270	3780					4400	2730	5.74
-3.0 m	kg													
-4.5 m	kg													

5.00 m Mono boom, 3.10 m arm, 2910 kg counterweight equipped and dozer blade down.

Lift-point height m		Lift-point radius										At max. Reach		
		1.5 m		3.0 m		4.5 m		6.0 m		7.5 m		Capacity	Reach	
														m
7.5 m	kg											*2680	*2680	5.62
7.0 m	kg							*3540	3030			*2420	2410	6.83
6.0 m	kg							*3780	2960	*2570	2030	*2340	2000	7.56
4.5 m	kg			*7570	*7570	*5230	4340	*4300	2820	3100	1980	*2390	1800	7.93
3.0 m	kg					*6470	4000	4220	2660	3030	1910	*2540	1730	8.00
1.5 m	kg			*6640	*6640	6270	3770	4090	2540	2820	1860	2820	1760	7.78
0.0 m	kg	*5170	*5170	*9310	6770	6170	3690	4020	2480			3100	1940	7.25
-1.5 m	kg	*8430	*8430	*9800	6880	6210	3720	4060	2520			3800	2370	6.31
-3.0 m	kg			*7000	*7000	*4610	3900					*4240	3670	4.72
-4.5 m	kg													

- Lifting capacity are based on ISO 10567.
- Lifting capacity of the HW A-series does not exceed 75% of tipping load with the machine on firm, level ground or 87% of full hydraulic capacity.
- The Lift-point is bucket pivot mounting pin on the arm (without bucket mass).
- (*) indicates load limited by hydraulic capacity.
- Caution: please be aware of the local regulations and instructions for lifting operations.

HW160A LIFTING CAPACITY

Rating over-front Rating over-side or 360 degrees

HW160A 2-PIECE BOOM

5.10 m 2-Piece boom, 2.00 m arm, 3410 kg counterweight equipped and dozer blade down.

Lift-point height m		Lift-point radius						At max. Reach				
		3.0 m		4.5 m		6.0 m		Capacity	Reach			
										m		
7.5 m	kg							*4660	*4660	4.30		
6.0 m	kg					*4250	*4250			*4310	3280	5.81
4.5 m	kg					*4880	4790	*4290	3080	4010	2600	6.65
3.0 m	kg					*6000	4470	4610	2970	3590	2310	7.07
1.5 m	kg					6840	4200	4470	2840	3470	2220	7.15
0.0 m	kg					6710	4080	4400	2770	3620	2310	6.91
-1.5 m	kg	*9910	7560	6710	4080	4410	2780	4140	2630			6.29
-3.0 m	kg											

5.10 m 2-Piece boom, 2.45 m arm, 3410 kg counterweight equipped and dozer blade down.

Lift-point height m		Lift-point radius										At max. Reach		
		3.0 m		4.5 m		6.0 m		7.5 m		Capacity	Reach			
												m		
7.5 m	kg											*3260	*3260	5.04
6.0 m	kg					*3940	*3940					*2790	*2790	6.37
4.5 m	kg					*3790	*3790	*3850	3180			*2620	2330	7.14
3.0 m	kg					*4450	*4450	*3990	3130			*2620	2100	7.54
1.5 m	kg					*5600	4540	*4460	2990	*2960	2120	*2600	2100	7.54
0.0 m	kg					*6720	4240	4490	2850	3240	2070	*2720	2030	7.61
-1.5 m	kg					6710	4080	4390	2760			*2980	2090	7.38
-3.0 m	kg	*8830	7460	6670	4050	4360	2740					*3520	2340	6.81
-4.5 m	kg					*6400	4130							

5.10 m 2-Piece boom, 2.60 m arm, 3410 kg counterweight equipped and dozer blade down.

Lift-point height m		Lift-point radius										At max. Reach		
		3.0 m		4.5 m		6.0 m		7.5 m		Capacity	Reach			
												m		
7.5 m	kg											*3450	*3450	5.23
6.0 m	kg					*3710	*3710					*2990	2730	6.52
4.5 m	kg					*3610	*3610	*3670	3180			*2830	2240	7.28
3.0 m	kg					*4270	*4270	*3850	3110			*2830	2240	7.28
1.5 m	kg					*5420	4540	*4340	2970	3270	2100	*2830	2020	7.67
0.0 m	kg					*6570	4210	4460	2830	3210	2040	*2960	1950	7.74
-1.5 m	kg					6660	4030	4350	2720	3180	2010	3170	2000	7.52
-3.0 m	kg	*8610	7370	6620	3990	4320	2690					3530	2230	6.96
-4.5 m	kg					*6480	4070							

- Lifting capacity are based on ISO 10567.
- Lifting capacity of the HW A-series does not exceed 75% of tipping load with the machine on firm, level ground or 87% of full hydraulic capacity.
- The Lift-point is bucket pivot mounting pin on the arm (without bucket mass).
- (*) indicates load limited by hydraulic capacity.
- Caution: please be aware of the local regulations and instructions for lifting operations.

HW160A

BUCKET SELECTION GUIDE & DIGGING FORCE

BUCKETS



SAE heaped m³	0.70	0.73	0.89	□ 0.69	○ 0.75
	0.76	0.85	1.05		

HW160A, 2910 kg counterweight equipped, dozer blade up.

Capacity m³		Width mm		Weight kg	Tooth EA	Recommendation mm			
SAE heaped	CECE heaped	Without side cutters	With side cutters			5000 Mono Boom			
						2000 Arm	2450 Arm	2600 Arm	3100 Arm
0.70	0.60	1020	1100	600	5	○	■	■	▲
0.76	0.65	1010	1170	620	5	■	■	▲	▲
0.89	0.77	1170	1325	680	6	▲	▲	×	×
1.05	0.90	1355	1510	740	6	×	×	×	×
0.69	0.62	1025	1025	720	5	○	■	▲	▲
0.75	0.65	1820	1820	540	0	○	■	■	▲
0.73	0.67	914	946	620	5	○	■	▲	▲
0.85	0.76	1067	1096	670	5	■	▲	▲	×

HW160A, 3410 kg counterweight equipped, dozer blade up.

Capacity m³		Width mm		Weight kg	Tooth EA	Recommendation mm						
SAE heaped	CECE heaped	Without side cutters	With side cutters			5000 Mono Boom			5100 2-Piece Boom			
						2000 Arm	2450 Arm	2600 Arm	3100 Arm	2000 Arm	2450 Arm	2600 Arm
0.70	0.60	1020	1100	600	5	●	○	■	■	○	■	■
0.76	0.65	1010	1170	620	5	○	■	■	▲	○	■	■
0.89	0.77	1170	1325	680	6	■	▲	▲	▲	■	▲	▲
1.05	0.90	1355	1510	740	6	▲	×	×	×	▲	×	×
0.69	0.62	1025	1025	720	5	○	■	■	■	○	■	■
0.75	0.65	1820	1820	540	0	○	○	■	■	○	■	■
0.73	0.67	914	946	620	5	○	■	■	■	○	■	■
0.85	0.76	1067	1096	670	5	■	▲	▲	▲	■	▲	▲

- Applicable for materials with density of 2100 kg/m³ or less
 - Applicable for materials with density of 1800 kg/m³ or less
 - Applicable for materials with density of 1500 kg/m³ or less
 - ▲ Applicable for materials with density of 1200 kg/m³ or less
 - ×
- Not Recommended

ATTACHMENT

Booms and arms are welded with low-stress, full-box section design. 2.0 m, 2.45 m, 2.6 m, 3.1 m arms are available.

DIGGING FORCE

Remarks:	Boom	Arm	5000 Mono				5120 2-piece				
			2000	2450	2600	3100	2000	2450	2600		
[]: Power Boost	Bucket digging force	SAE	kN	98.2 [106.6]	98.0 [106.4]	98.4 [106.8]	98.4 [106.8]	98.2 [106.6]	98.0 [106.4]	98.4 [106.8]	
			kgf	10008.4 [10866.3]	9991.7 [10848.2]	10025.7 [10885.0]	10029.3 [10889.0]	10008.4 [10866.3]	9991.7 [10848.2]	10025.7 [10885.0]	
			ISO	kN	115.0 [124.9]	114.8 [124.7]	115.2 [125.1]	115.3 [125.2]	115.0 [124.9]	114.8 [124.7]	115.2 [125.1]
		kgf	11725.9 [12730.9]	11706.3 [12709.7]	11746.1 [12752.9]	11750.3 [12752.5]	11725.9 [12730.9]	11706.3 [12709.7]	11746.1 [12752.9]		
		Arm crowd force	SAE	kN	92.4 [100.3]	73.3 [79.5]	72.6 [78.8]	64.5 [70.0]	92.4 [100.3]	73.3 [79.5]	72.6 [78.8]
				kgf	9416.6 [10223.7]	7467.6 [8107.7]	7401.4 [8035.8]	6572.2 [7135.5]	9416.6 [10223.7]	7467.6 [8107.7]	7401.4 [8035.8]
ISO	kN		97.4 [105.7]	76.7 [83.2]	75.9 [82.4]	67.0 [72.8]	97.4 [105.7]	76.7 [83.2]	75.9 [82.4]		
			kgf	9928.2 [10779.2]	7815.9 [8485.8]	7737.3 [8400.5]	6832.8 [7418.5]	9928.2 [10779.2]	7815.9 [8485.8]	7737.3 [8400.5]	

Note : Arm weight includes bucket cylinder, linkage, and pin

HW140A / HW160A

STANDARD/OPTIONAL EQUIPMENT

ENGINE	HW140A	HW160A
Cummins B4.5 engine	●	●

HYDRAULIC SYSTEM	HW140A	HW160A
Advanced Load Sensing (LUDV)		
3-power modes, 3-work modes, user mode	●	●
Power Boost Function	●	●
Attachment Flow Control	●	●
3 attachment control modes (Push/Prop/Permanent)	●	●
Engine Auto Idling	●	●
Engine Auto Shutdown	●	●
Electronic Fan Control (reversible)	●	●
40 km/h or 20 km/h travel motor	●	●
Hyundai Bio Hydraulic Oil (HBHO)	●	●

CAB & INTERIOR	HW140A	HW160A
----------------	--------	--------

ISO Standard cabin		
All-weather steel cab with 360° visibility	●	●
Parallel type windshield wiper	●	●
Radio / USB / MP3 player	●	●
Handsfree mobile phone system with USB	●	●
12 volt power outlet (24V DC to 12V DC converter)	●	●
Electric horn	●	●
Safety glass - Tempered glass with front laminated glass	●	●
Safety glass windows	●	●
Sliding fold-in front window	●	●
Sliding side window(LH)	●	●
Lockable door	●	●
Hot & cool box	●	●
Storage compartment	●	●
Transparent cabin roof-cover	●	●
Cabin lights	●	●
Cabin front window rain guard	●	●
Sun visor	●	●
Door and cab locks, one key	●	●
Smart key & Start button	●	●
Pilot-operated proportional joysticks	●	●
Steering wheel with 3-way adjustable steering column	●	●
Automatic climate control		
Air conditioner & heater	●	●
Defroster	●	●
Starting Aid (air grid heater) for cold weather	●	●
Centralized monitoring		
8" LCD touchscreen display	●	●
Engine speed or trip meter/Accel.	●	●
Engine coolant temperature gauge	●	●
Max power	●	●
Low speed/High speed	●	●
Auto idle	●	●
Overload warning with alarm	●	●
Check Engine	●	●
Air cleaner clogging	●	●
Indicators	●	●
ECO Gauge	●	●
Fuel level gauge	●	●
Hyd. oil temperature gauge	●	●
Warnings	●	●
Communication error	●	●
Low battery	●	●
Clock	●	●
Seat		
Adjustable air suspension seat with heater	●	●
Mechanical suspension seat with heater		
Cabin ROPS (ISO 12117-2)		
ROPS (Roll Over Protective Structure)	●	●
Cabin FOPS/FOG (ISO 10262) Level 2		
FOPS (Falling Object Protective Structure)	●	●
FOG (Falling Object Guard)	Front & Top Guard Top Guard	

SAFETY	HW140A	HW160A
--------	--------	--------

Safety lock valve on boom cylinders with overload warning device	●	●
Safety lock valve on arm cylinder	●	●
Safety lock valve on dozer blade cylinder	●	●
Safety lock valve on front axle oscillation cylinders	●	●
Four outside rearview mirrors	●	●
Rearview camera	●	●
Rear & Mirrorview camera		
Rear Radar & 2nd monitor		
AAVM (Advanced Around View Monitoring)		
Four front working lights LED (2 boom mounted, 2 front frame mounted)	●	●
Rear work lamp LED	●	●
Beacon lamp LED		
Travel alarm	●	●
Automatic swing brake	●	●
Swing Lock System		
Auto-digging brake		
Joystick Steering		
Battery master switch	●	●
Wheel chock	●	●

ATTACHMENT	HW140A	HW160A
------------	--------	--------

Boom options		
4.60 m Mono	●	-
4.71 m 2-Piece		-
5.0 m Mono	-	●
5.1 m 2-Piece	-	
Arm options		
2.00 m		
2.45 m	●	●
2.60 m		
3.10 m		

OTHER	HW140A	HW160A
-------	--------	--------

Ride control (boom suspension system)		
Boom floating system		
Cruise control	●	●
Speed Limiter	●	●
Creep speed travel mode	●	●
Heavy counterweight		
Removable clean-out dust net for cooler	●	●
Fuel pre-filter	●	●
Self-diagnostics system	●	●
Hi MATE (Remote Management System)	Mobile Satellite	●
Batteries (2 x 12V x 100 AH)	●	●
Fuel filler pump (35 lpm) with autostop	●	●
Single-acting piping kit (breaker, etc.)	●	●
Double-acting piping kit (clamshell, etc.)	●	●
Rotation Piping Kit		
Quick coupler piping		
Quick coupler		
Accumulator for lowering work equipment	●	●
Pattern change valve (2 patterns)		
Fine Swing Control		
Tool kit	●	●
Lower Frame Toolbox - LH	●	●
Lower Frame Toolbox - LH, RH		

UNDERCARRIAGE	HW140A	HW160A
---------------	--------	--------

Rear dozer blade	●	●
Front dozer blade		
Rear outrigger		
Front and rear outrigger		
Front outrigger and rear blade		
Front blade and rear outrigger		
Front grapple rest and rear blade		
Front grapple rest and rear outrigger		
Trailer hitch preparation kit for rear dozer blade		
Tyres-dual (10.00-20-14PR tube)	●	
Tyres-dual (10.00-20-16PR tube)		●
Tyres-dual (10.00-20 solid)		
Fenders (Mudguards)	●	●

- * Standard and optional equipment may vary. Contact your Hyundai dealer for more information.
- The machine may vary according to International standards.
- * The photos may include attachments and optional equipment that are not available in your area.
- * Materials and specifications are subject to change without advance notice.



Specifications and design are subject to change without notice. Pictures of Hyundai Construction Equipment Europe products may show other than standard equipment.

Hyundai Construction Equipment Europe nv,
Hyundailaan 4, 3980 Tessenderlo, Belgium.
Tel: (32) 14-56-2200 Fax: (32) 14-59-3405

EN-2021_05 Rev 0

Ready to aim high?

Contact your Hyundai dealer.
hyundai-ce.eu/en/dealer-locator