

COMPACT EXCAVATOR

# HX10A



**The HX10A Compact Excavator is part of Hyundai's brand new A-series:**

a fresh generation of construction equipment that complies with the European stage V emission levels. But it does much more than that! While fulfilling regulatory demands, Hyundai aimed for a ground-breaking level of customer satisfaction with maximum performance and productivity, better safety, more convenience and improved uptime management.

From a slim, practical design that works in the tightest spaces to an optional electro-hydraulic unit for emission-free operation, the HX10A opens up a world of new possibilities where tiny efforts move mountains. It's time to experience the Hyundai Effect!



**READY TO  
CHANGE YOUR  
WORLD**

**ENTER**  
**A WORLD**  
**WHERE**  
**ANYTHING**  
**IS POSSIBLE**



## Durability/Safety

- Foldable ROPS bar
- Sturdy design
- Protected hydraulic lines
- External hydraulic oil tank
- Top mounted boom cylinder
- Working light
- Compact dimensions

## Comfort

- Adjustable driver seat
- Simple operational controls
- Clear indicators

## Serviceability

- Excellent accessibility
- No-maintenance & leak-free swing motor
- Large engine cover

## Productivity

- Powerful 3-cylinder engine
- Variable undercarriage
- Extendable dozer blade
- Various buckets
- Boom swing function
- Dual power (option)
- Secondary auxiliary hydraulics circuit (option)

# THE PERFECT FIT - WHEREVER YOU'RE WORKING

The HX10A was designed with one priority in mind: your needs. As soon as you settle into the adjustable ergonomic seat, you enter a new world of comfort and convenience. The controls are simple and intuitive, while the slim design, foldable Roll Over Protection System (ROPS) bar, and swing post-mounted mono-boom enable easy access through doorways and inside buildings.

The excavator's light weight (just 1,000 kg) and small dimensions make it easy to transport between jobs. Add the optional electro-hydraulic unit and it can even be operated electrically and emission-free, extending its applications to numerous indoor and urban tasks.



▲ In addition to the integrated diesel engine, the HX10A can be powered by an optional electro-hydraulic unit for low noise, zero-emissions operation. This makes it the ideal choice for work indoors or in sensitive environments. The generator is simply connected to the undercarriage and has no impact on machine handling or performance, even in breaker operation.

◀ Simple controls and clear indicators of machine status make operation easy and intuitive.

**“Indoors and outdoors, whether it’s demolition, remodelling or excavation, the HX10A gets the job done with no fuss.”**



The HX10A's powerful three-cylinder engine delivers ample power on a wide range of tasks, from gardening and landscaping to construction sites in residential areas, demolition tasks and indoor use. It operates with optimal fuel efficiency and minimal emissions to ensure compliance with environmental regulations.

This little workhorse is designed for extreme versatility, enabling you to get the most out of every working day in almost any environment. The mono-boom is mounted on a swing-post, making it possible to dig close to walls and across the entire width of the machine. The dozer and track can be quickly retracted and the ROPS bar can be folded down, allowing trouble-free passage through doors, corridors and alleyways.

Hydraulic hammer piping is integrated as standard for efficient hammer operation inside buildings.



The extendable dozer blade allows for grading over the full width of the track.

The variable undercarriage guarantees trouble-free passage through doors, corridors and alleyways



# WORK EFFICIENTLY IN THE TIGHTEST SPACES



**"It's light and easy to transport between sites and I can drive it through almost any passage or doorway. It's ideal for indoor demolition jobs!"**

# PROTECTION FOR YOU AND YOUR MACHINERY

Small details make a big difference when it comes to safety. We designed the HX10A to offer maximum protection for you, your worksite and your investment without compromising on productivity. Operators are protected by a sturdy two-column ROPS that can be easily folded when necessary to facilitate building entry through a standard door.

Compact dimensions, zero swing and all-round visibility help operators to work more confidently when space is restricted, while a variable undercarriage increases stability when working on uneven surfaces. The overall design is solid and sturdy, featuring rugged cast-iron reinforcements. For added machine protection, all hydraulic hoses are routed inside the boom, which features a top-mounted cylinder to prevent damage.

The foldable ROPS bar offers protection for operators working in narrow spaces.

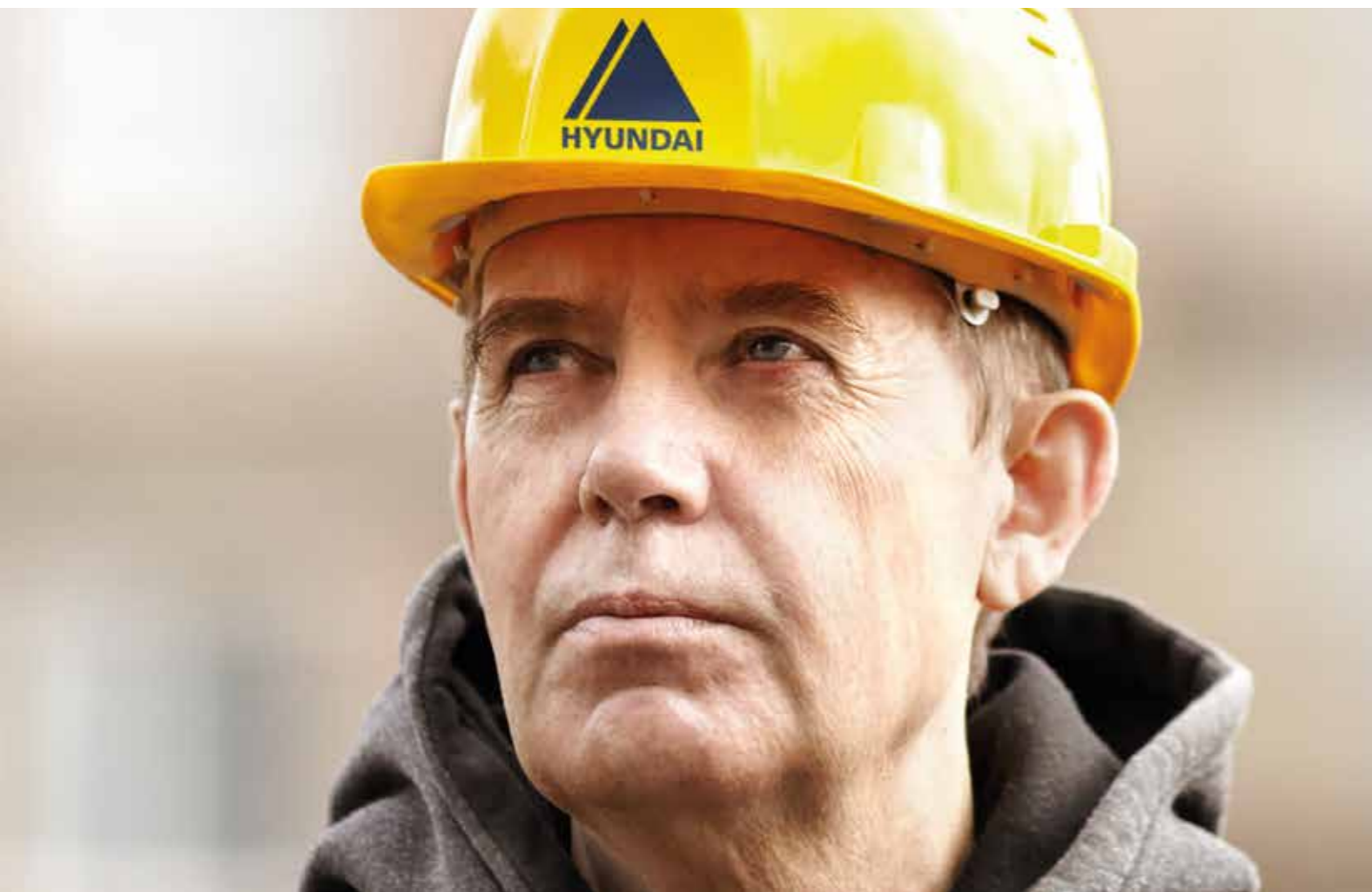

“My aim is to completely eliminate risks and accidents from my worksites. Hyundai is helping me to reach that goal.”



A powerful working light ensures good visibility when working indoors or at night.



“I need all my machines up and running to protect my business. I know I can rely on the HX10A.”

You need to know that the investment you make today will help to sustain your profits over the long term. That’s why we prioritised reliability and durability throughout the development of the HX10A, from design and manufacturing to quality control. Every component has been selected for long, trouble-free service. The hydraulic system features high-grade hoses with superior heat resistance to ensure an extended lifetime, even in rough working conditions.

Downtime for servicing has been reduced to a minimum by making parts easy to access and replace when necessary. The swing motor is leak-free and requires no maintenance. Even the attachments have been rigorously tested to ensure excellent wear resistance and lasting performance.

# MAXIMUM UPTIME TO PROTECT YOUR BUSINESS

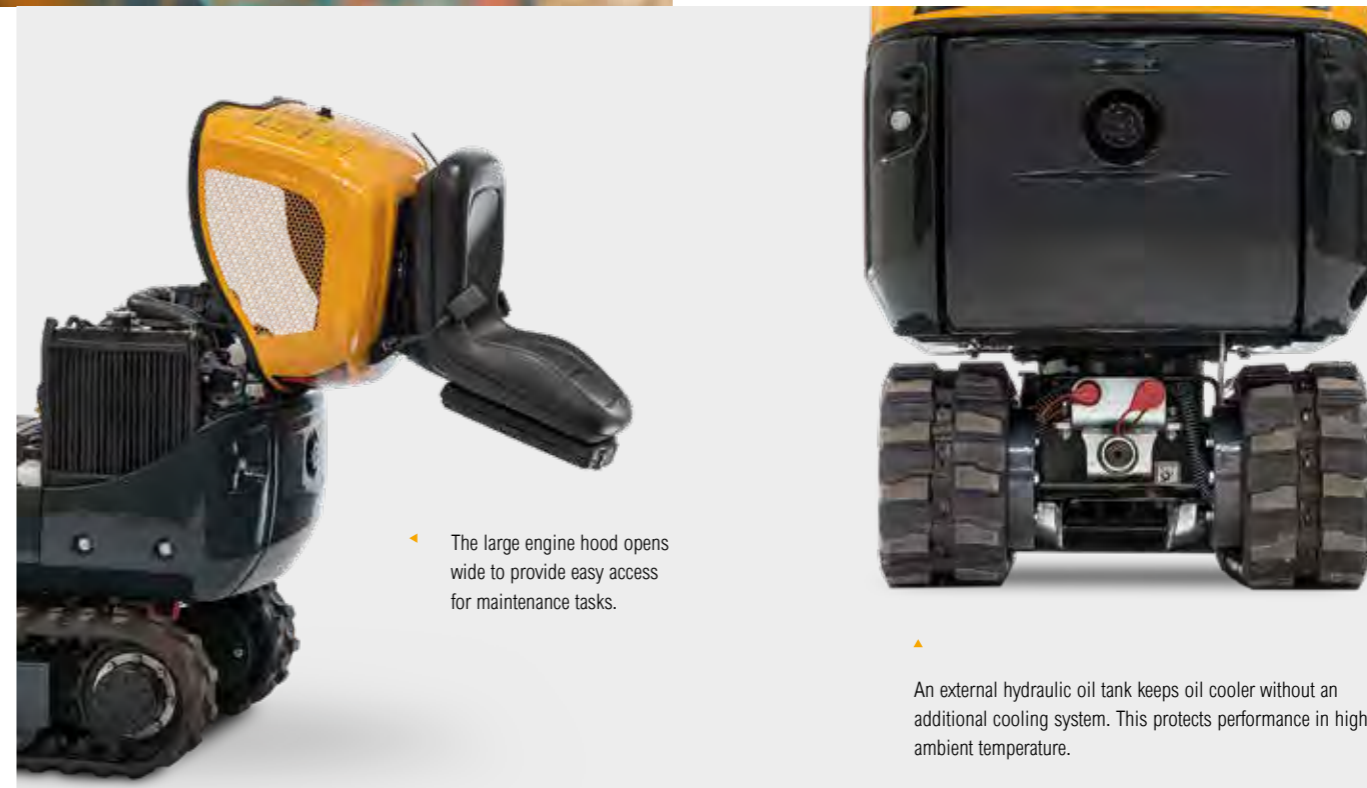

◀ The large engine hood opens wide to provide easy access for maintenance tasks.

▲ An external hydraulic oil tank keeps oil cooler without an additional cooling system. This protects performance in high ambient temperature.

# FOCUSED TECHNOLOGIES FOR THE RESULTS YOU WANT

Hyundai A-series compact excavators are designed to create better conditions for operators and deliver the ultimate ownership experience. Every detail is carefully fine-tuned to match your needs in the field, including better safety and comfort, higher productivity, maximum uptime and easy servicing. It's all part of the Hyundai Effect.

See more at [hyundai-ce.eu](http://hyundai-ce.eu)



## SPECIFICATIONS

ENGINE	
Maker / Model	Yanmar 3TNV70 / STAGE V
Type	Water-cooled four stroke diesel engine 3-cylinder indirect injection
Rated flywheel horse power	9,9 kW (13.3 HP) @ 2,100 rpm
Max. Torque	5,3 kgf.m (38 lbf.ft) @ 1,500 rpm
Bore x stroke	70 x 74 mm (2.8" x 2.9")
Piston displacement	854 cc (52.3 cu in)
Battery	12 V 30 Ah
Starting motor	12 V - 1.1 kW
Alternator	12 V - 20 A

HYDRAULIC SYSTEM	
<b>MAIN PUMP</b>	
Type	Twin gear pump 2 x 4 cm <sup>3</sup> (2 x 0.24 in <sup>3</sup> )
Max. Flow	2 x 10.7 l/min @ 2675 rpm (2 x 2.8 gpm @ 2675 rpm)
Sub-pump for pilot circuit	n/a

HYDRAULIC MOTORS	
Travel	Slow-running drive motor without gears and with internal leak oil drain
Swing	Slow-running swing motor without gears with automatic break

RELIEF VALVE SETTING	
Travel	170 ±3 bar (2466 psi)
Swing circuit	70 bar (1015 psi)

OPERATOR'S CABIN	
Sound power level (LWA) 1	93 dB (A)
Operator-perceived sound pressure level (LPA) 2	77 dB (A)

COOLANT & LUBRICANT CAPACITY			
	liter	US gal	UK gal
Fuel tank	7	1.85	1.54
Engine coolant	2,9	0.77	0.64
Engine oil	2,5	0.66	0.55
Hydraulic tank	13,8	3.65	3.03

HYDRAULIC CONTROLS	
Pilot control	Two joysticks - mechanically operated
Engine throttle	Two travel levers - mechanically operated

SWING SYSTEM	
Swing speed	8 rpm
Tail swing radius	747 mm (29 in)

DRIVES & BRAKES	
Max. travel speed (high) / (low)	1.82 km/h (1.1 mph)
Maximum gradeability	30°/58 %

DIGGING FORCE (ISO)	
Bucket breakout force	8.9 kN (2001 lbf)
Arm crowd force	4.5 kN (1012 lbf)

OPERATING WEIGHT (WITH ROLLBAR)	
Operating weight*	1087 kg (2396 lbs)
Transport weight**	990 kg (2182 lbs)
Track Width	180 mm (7 in)
Ground pressure	0.24 kg/cm <sup>2</sup> (3.4 lbs/in <sup>2</sup> )

\* Service weight: basic machine + full fuel tank + backhoe bucket (250 mm/10 in) + user (75 kg/165 lbs).

\*\* Transport weight: basic machine + 10% fuel capacity.

UNDERCARRIAGE	
Travel gear width (retracted/extended)	700/860 mm (2'-4"/2'-10")
Blade width (folded in/out)	700/860 mm (27.55"/33.85")
No. of track roller on each side	2

HYDRAULIC SYSTEM	
Operating pressure at connection	Max. 170 bar (2466 psi)
Flow rate	Max. 20 l/min (5.3 gal/min)

DIMENSIONS		
Height	Dimensions model with rollbar	2,261 mm (89 in)
	Dimensions model without rollbar	1,436 mm (57 in)
Upper carriage width	730 mm (29 in)	
Width with retracted / extended telescopic travel gear	700 / 860 mm (28 / 34 in)	
Width with stabilizer blade folded in / out	700 / 860 mm (28 / 34 in)	
Transport length	2,747 (9')	
Max. digging depth	1,766 mm (70 in)	
Stick length	890 mm (35 in)	
Max. vertical digging depth	1,320 mm (52 in)	
Max. digging height	2,853 mm (9'-4")	
Max. tilt-out height	2,008 mm (79 in)	
Max. digging radius	3,092 mm (10'-2")	
Max. reach at ground level	3,046 mm (10')	



# DIMENSIONS & WORKING RANGE

HX10A DIMENSIONS	
Overall length	2,747 mm (108 in)
Overall height	1,436 mm (57 in)
Overall width	730 mm (29 in)
Tail swing radius	747 mm (29 in)
Track length	1,220 mm (48 in)
Track gauge	700 - 860 mm (28 - 34 in)
Track shoe width	180 mm (7 in)
Ground clearance	130 mm (5 in)

HX10A WORKING RANGE	
Boom length	1,320 mm (52 in)
Arm length	890 mm (35 in)
Max. digging reach	3,092 mm (122 in)
Max. digging reach at ground	3,046 mm (120 in)
Max. digging depth	1,766 mm (70 in)
Max. vertical wall digging depth	1,320 mm (52 in)
Max. digging height	2,853 mm (112 in)
Max. dump height	2,006 mm (79 in)
Min. front swing radius	1,039 mm (41 in)

# LIFTING CAPACITY

A	Reach from live ring center
B	Height

All table indications in kg (lbs) and horizontal position on firm and level ground, and without bucket or attachment.  
 Calculation basis: according to ISO 10567.  
 Setting pressure on boom cylinder: 17000 kPa (2466 psi)  
 The machine's lift capacity is restricted by the hydraulic output and the hydraulic system's stabilizing features.  
 Neither 75% of the static tilt load nor 87% of the hydraulic lift capacity is exceeded.

- The lift capacity applies under the following conditions:
- Lubricants and engine/vehicle fluids at the mandatory levels
  - Full fuel tank
  - Machine at operating temperature
  - Operator weight: 75 kg (165 lbs)
  - Telescopic travel gear extended

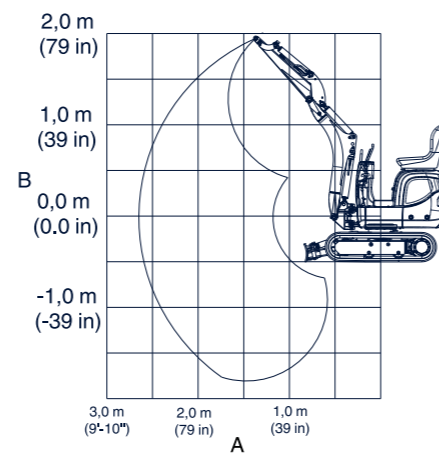

# LIFTING CAPACITY

LONGITUDINAL DIRECTION, DOZER BLADE AT FRONT AND LOWERED						
A/B			2.5 m (98 in)	2.0 m (79 in)	1.5 m (59 in)	1.0 m (39 in)
	A max (m/ft)	kg/lbs				
2.4 m (94 in)	1.41 (4.61)	216 (477)	--	--	--	--
2.0 m (79 in)	2.03 (6.64)	205 (453)	--	203 (448)	--	--
1.5 m (59 in)	2.40 (7.86)	191 (420)	--	189 (416)	--	--
1.0 m (39 in)	2.59 (8.49)	177 (391)	185 (407)	217 (478)	247 (544)	--
0.5 m (20 in)	2.65 (8.7)	166 (365)	184 (407)	247 (544)	366 (807)	--
0.0 m (0.0 in)	2.60 (8.52)	155 (343)	171 (377)	247 (544)	379 (835)	678 (1495)
-0.5 m (-20 in)	2.41 (7.91)	146 (323)	--	215 (475)	325 (718)	561 (1236)
-1.0 m (-39 in)	2.05 (6.73)	138 (304)	--	149 (328)	243 (536)	418 (922)

LONGITUDINAL DIRECTION, DOZER BLADE AT REAR						
A/B			2.5 m (98 in)	2.0 m (79 in)	1.5 m (59 in)	1.0 m (39 in)
	A max (m/ft)	kg/lbs				
2.4 m (94 in)	1.41 (4.61)	216 (477)	--	--	--	--
2.0 m (79 in)	2.03 (6.64)	205 (453)	--	203 (448)	--	--
1.5 m (59 in)	2.40 (7.86)	175 (386)	--	189 (416)	--	--
1.0 m (39 in)	2.59 (8.49)	154 (339)	162 (358)	217 (478)	247 (544)	--
0.5 m (20 in)	2.65 (8.7)	146 (322)	159 (351)	220 (484)	335 (738)	--
0.0 m (0.0 in)	2.60 (8.52)	148 (327)	156 (344)	213 (469)	320 (705)	618 (1363)
-0.5 m (-20 in)	2.41 (7.91)	146 (323)	--	210 (462)	316 (696)	561 (1236)
-1.0 m (-39 in)	2.05 (6.73)	138 (304)	--	149 (328)	243 (536)	418 (922)

LONGITUDINAL DIRECTION, DOZER BLADE AT FRONT AND RAISED						
A/B			2.5 m (98 in)	2.0 m (79 in)	1.5 m (59 in)	1.0 m (39 in)
	A max (m/ft)	kg/lbs				
2.4 m (94 in)	1.41 (4.61)	216 (477)	--	--	--	--
2.0 m (79 in)	2.03 (6.64)	205 (453)	--	203 (448)	--	--
1.5 m (59 in)	2.40 (7.86)	163 (358)	--	189 (416)	--	--
1.0 m (39 in)	2.59 (8.49)	142 (314)	151 (332)	212 (469)	247 (544)	--
0.5 m (20 in)	2.65 (8.7)	135 (298)	147 (325)	204 (450)	311 (685)	--
0.0 m (0.0 in)	2.60 (8.52)	137 (303)	145 (319)	197 (434)	296 (653)	570 (1257)
-0.5 m (-20 in)	2.41 (7.91)	146 (323)	--	194 (428)	292 (644)	561 (1236)
-1.0 m (-39 in)	2.05 (6.73)	138 (304)	--	149 (328)	243 (536)	418 (922)

CROSSWISE						
A/B			2.5 m (98 in)	2.0 m (79 in)	1.5 m (59 in)	1.0 m (39 in)
	A max (m/ft)	kg/lbs				
2.4 m (94 in)	1.41 (4.61)	216 (477)	--	--	--	--
2.0 m (79 in)	2.03 (6.64)	167 (367)	--	170 (376)	--	--
1.5 m (59 in)	2.40 (7.86)	126 (277)	--	172 (378)	--	--
1.0 m (39 in)	2.59 (8.49)	109 (240)	116 (255)	166 (366)	247 (544)	--
0.5 m (20 in)	2.65 (8.7)	103 (227)	113 (248)	158 (347)	241 (531)	--
0.0 m (0.0 in)	2.60 (8.52)	104 (230)	110 (242)	150 (332)	226 (499)	431 (951)
-0.5 m (-20 in)	2.41 (7.91)	115 (253)	--	148 (325)	222 (490)	433 (955)
-1.0 m (-39 in)	2.05 (6.73)	138 (304)	--	149 (328)	225 (497)	418 (922)



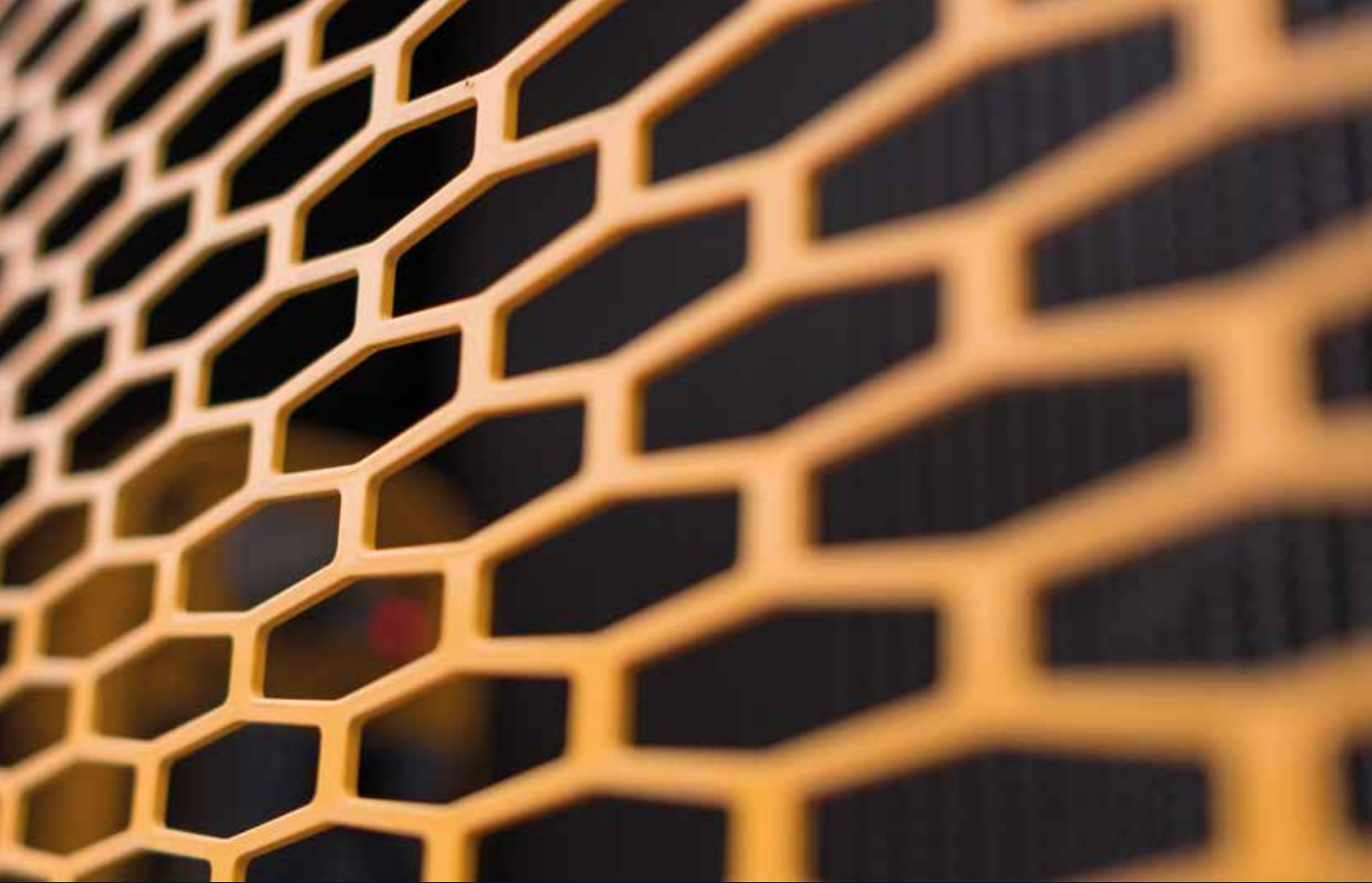

Specifications and design are subject to change without notice. Pictures of Hyundai Construction Equipment Europe products may show other than standard equipment.

Hyundai Construction Equipment Europe nv, Hyundailaan 4, 3980 Tessenderlo, Belgium. Tel: (32) 14-56-2200 Fax: (32) 14-59-3405

EN - 2020.01 Rev 1

**Ready to experience the Hyundai Effect?**

**Contact your Hyundai dealer.**

**[hyundai-ce.eu/en/dealer-locator](https://hyundai-ce.eu/en/dealer-locator)**

