

CRAWLER EXCAVATOR

HX235A LCR



READY TO CHANGE YOUR WORLD

The HX235A LCR Crawler Excavator is part of Hyundai's new A-series: a fresh generation of construction equipment that complies with the European stage V emission levels. But it goes much further than that! While fulfilling regulatory demands, Hyundai aimed for a ground-breaking level of customer satisfaction with maximum performance and productivity, better safety, more convenience and improved uptime management.

With a compact swing radius that lets you work safely and efficiently in tight spaces, this machine opens up a world of new possibilities where tiny efforts move mountains. It's time to experience the Hyundai Effect!



Productivity & Efficiency

COMPACT AND POWERFUL TO BOOST YOUR PROFITS

The HX235A LCR features the new A-series upper frame design, which significantly increases lifting capacity. This is combined with reduced tail swing and a new lifting mode, to make this powerful machine an excellent all-rounder for digging and moving heavy loads.

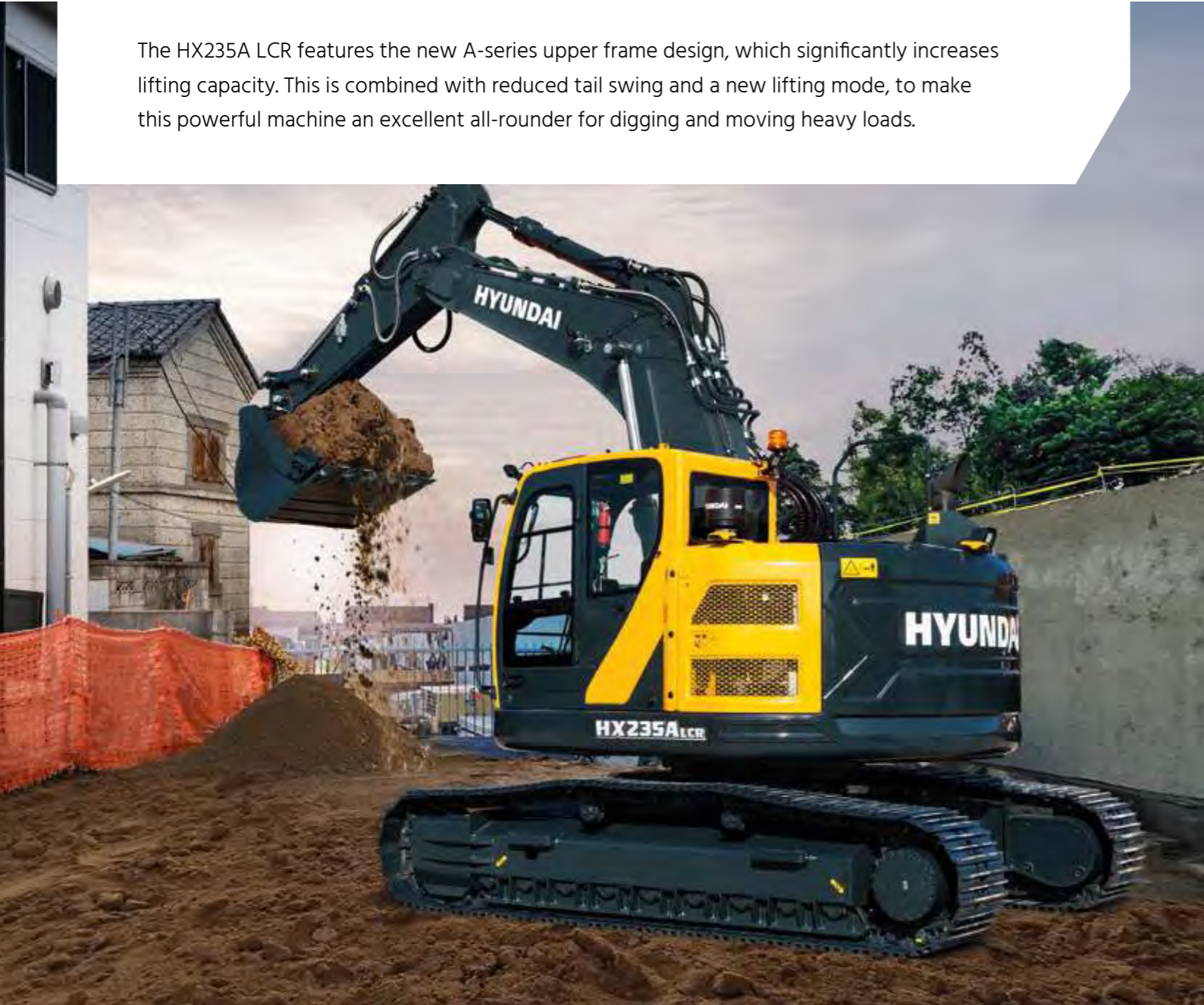

Compact Radius

The HX235A LCR (Compact Radius) features a short rear tail with a curved counterweight that rolls along the tracks with minimal overhang. This minimises outswing of the machine's rear end, giving operators peace of mind when working in space-restricted areas. Durability is also improved as the risk of the machine colliding with nearby walls or obstacles is greatly reduced.

Stable and powerful

Despite its compact design, the HX235A LCR is remarkably stable when lifting and transporting heavy objects or materials. The centred boom concept delivers superb lift capacity while the sturdy undercarriage provides stability and extra confidence when working on uneven surfaces.



Automatic engine shutdown

The engine shuts down automatically when the machine is at rest to cut fuel consumption and emissions. Different operating modes and idling times can be selected according to the work environment, further enhancing efficiency.

NEW

Lifting mode

This work mode improves precision and lift capability through RPM reduction, power boost activation and enhanced pump flow control.



NEW

Engine

The HX235A LCR is equipped with an eco-friendly Cummins B6.7 engine that satisfies the strictest emissions requirements. It also delivers impressive power and performance with 881 Nm of peak torque (31% more than its predecessor) setting a new industry benchmark. Like all A-Series machines, this excavator features our all-in-one exhaust aftertreatment system. Removing the need for EGR has also enabled us to improve productivity through better fuel economy and longer service intervals.



Tier4 Final(2014)
EU Stage-V(2019)



Fuel rate information

Average and latest fuel consumption data is displayed to guide operators towards more economical operation.

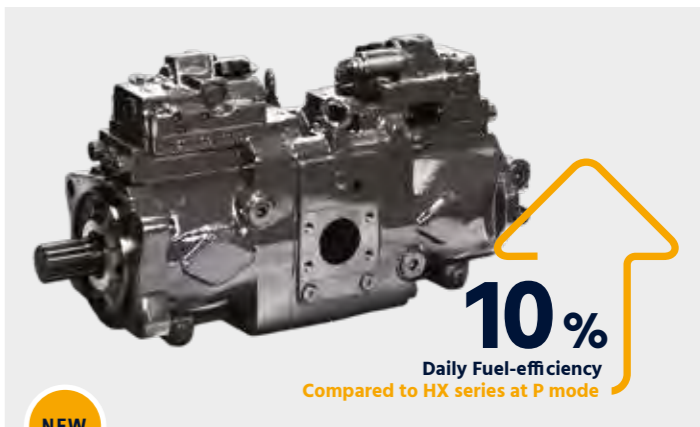

NEW

EPFC (Electronic Pump Flow Control)

EPFC improves fine control while also reducing fuel consumption. The system allows operators to tailor their machine for the job at hand, ensuring the optimal balance of power and precision.

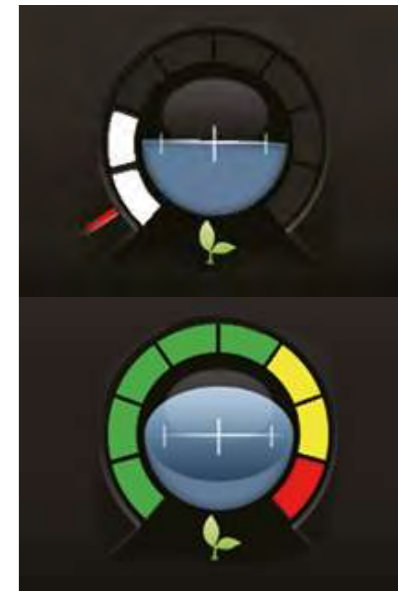

Eco Gauge

This feature helps operators to reduce emissions and running costs by displaying the engine workload and fuel-saving status.

Eco Report

The Eco Report feature makes it easy for operators to develop efficient working habits by displaying real-time information about machine performance.

NEW



Durability

READY FOR ACTION AND BUILT TO LAST

You need to know that the investment you make today will help to sustain your business over the long term. That's why we prioritised reliability throughout the development of the HX235A LCR, from design and manufacturing to quality control. We improved engine reliability by removing the EGR and integrating exhaust after treatment with a simplified, single-module system that's easier to maintain. The upper and lower frame structures are reinforced for high load work, while the attachments have been rigorously tested for the roughest conditions. The overall aim is to minimise downtime and repairs so that you can stay on schedule, avoid unexpected costs and protect your profits.



“Strength and reliability are built into every single component.”

Bucket and attachments

As well as rigorously testing and reinforcing all attachments for durability, we have improved the wear resistance of the bucket by using a new material.



Cooling module

HX A-Series machines are enhanced with a durable cooling module that has been stringently tested to protect productivity in tough working environments.



Cabin structure

The cabin structure is reinforced with integrally welded, low-stress, high-strength steel. It is certified to ISO 12117-2 (ROPS - Roll-over Protective Structures) and ISO 10262 Level 2 (FOPS - Falling Object Protective Structures) safety standards.

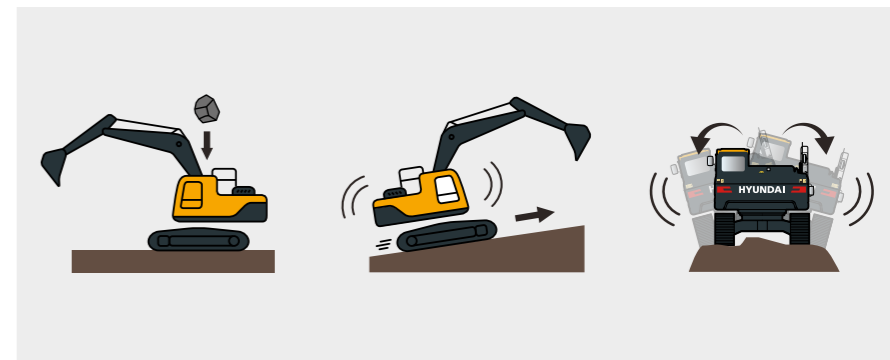

Hydraulic hoses

High-grade hoses with outstanding resistance to heat and pressure provide maximum durability, even in rough working conditions.

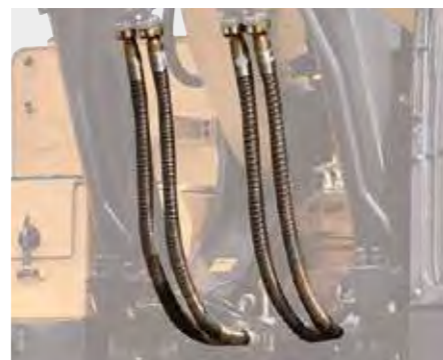

Operator Comfort

A CABIN DESIGNED AROUND YOU

The cabin is designed to provide every operator with a comfortable working environment that boosts productivity and reduces fatigue. It includes a high-quality seat and a well thought-out layout that places the most important controls within easy reach. A range of options help you to tailor the cabin to your needs, including a new audio system with radio, USB, AUX input and Bluetooth to keep you connected and entertained. The overall design places you right at the centre of the Hyundai Effect, with a world of convenience at your fingertips.



“The ideal workplace – I feel relaxed, alert and in full control.”



Key On Init Work Mode

This feature allows operators to save the attachment mode setting so that the machine is automatically in the right work mode when re-starting.



Owner Menu Editing (OME)

Menu functions can be set by the machine owner, who can also provide or restrict access for machine users by using a password to lock or unlock the list.



Combination speed setting system

This system allows operators to balance load sensitivity and boom priority against arm and swing. Select from five levels of load sensitivity to adjust initial flow rate for boom-up and arm-in operation according to attachment weight. Ten levels of boom priority can be selected to balance boom operation against arm and swing.



Wide touchscreen monitor

The HX235A LCR features an 8-inch display with a touchscreen and excellent legibility. All the indicators displaying machine status are centralised in one cluster to enable easy, efficient control.



Improved visibility and access

The open design of the cabin door gives the operator a clear, unimpeded view to the exterior. The door handle has also been redesigned for safer, more convenient access. The right-hand side of the machine also features a new design that gives the operator a better view of the bottom right side of the excavator.



Front side air vent

An air vent at the front of the cabin keep you cool as you work.

Proportional auxiliary hydraulic control

The optional proportional control system can be operated using sliders on the gearstick, offering the operator more efficient and convenient control over the speed of work tools, especially in jobs requiring high precision or full-speed operation. Alternatively, control of the system can be switched over to a foot pedal via the settings menu.

OPTION

Fine swing control

Fine cushion swing control enables smooth movement at the beginning and end of swing operations. Fine free swing control reduces shaking of the weight during lifting.

OPTION

Miracast connectivity

The Miracast system based on the operator's smartphone Wi-Fi allows the use of various smartphone features on the screen, including navigation, web surfing and music and video playback.



New audio system

The new audio system has a radio, USB-based MP3 player, integrated Bluetooth hands-free technology and a built-in microphone for convenient call handling. The radio has been repositioned to the right for easier reach to the controls.

NEW



Safety

PROTECTION FOR YOUR CO-WORKERS AND EQUIPMENT

Small details can make a huge difference when it comes to safety and security. The HX235A LCR offers all-round protection for you, your workmates and your machinery. The cabin allows optimal visibility, while optional Advanced Around View Monitoring (AAVM) gives you a clear overview of your surroundings. By helping to ensure an accident-free worksite, this crawler excavator contributes to the peace of mind and productivity that form part of the Hyundai Effect.



“The compact swing radius adds an extra layer of protection for the excavator and for workers and objects on site.”



Seat belt warning alarm
Operators are reminded to fasten their safety belt by an audible and visible alarm.

OPTION

Advanced Around View Monitoring (AAVM)
The AAVM camera system gives you a 360° overview of your immediate working environment. It also includes Intelligent Moving Object Detection (IMOD) technology that senses and warns you when people or objects come within five metres of the machine.

Electronic swing parking system
The swing brake is controlled by an electronic valve and control system to improve safety and efficiency.

NEW

Auto safety lock
The auto safety lock feature prevents unintentional ignition. When the lock is activated, the excavator is not controlled by the RCV lever.

NEW

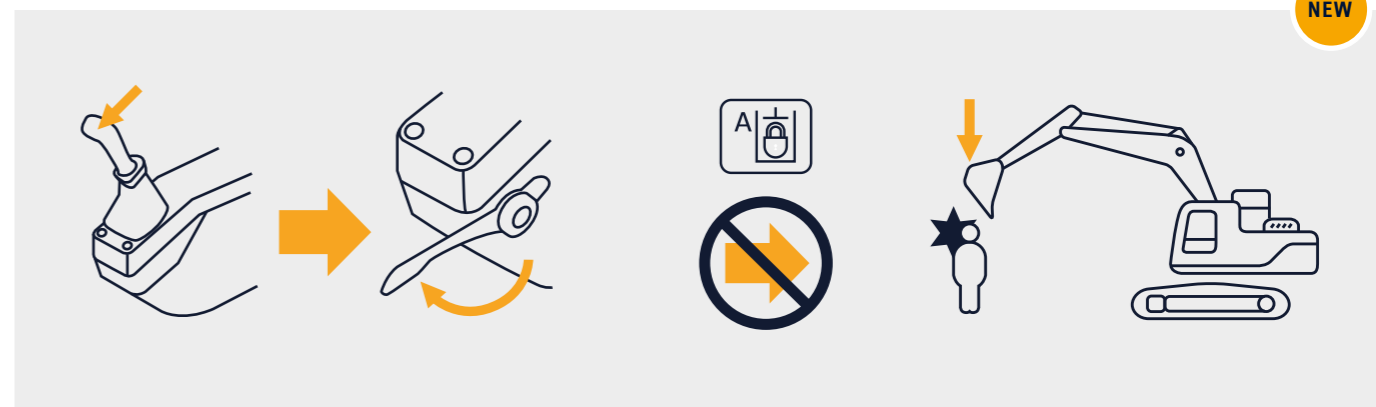

Serviceability & Connectivity

ADVANCED DIAGNOSTICS AND SERVICING SUPPORT

The peace of mind that comes with quick, low-effort servicing is also part of the Hyundai Effect. The HX235A LCR is designed to make maintenance as convenient as possible. All components and materials have been optimised to ensure a long, trouble-free life. Hyundai's innovative Hi MATE telematics system enables full monitoring of machine activity and performance. Maximum connectivity is integrated to help you create a smart construction site and protect your profitability.

"The new technologies make it easy to keep track of servicing tasks and get extra support if I need it."

HCE Diagnostic Tools (HCE-DT) app

Technicians can connect wirelessly to the machine on-site using a smartphone or laptop. A quick check can be performed to diagnose the root cause of a failure or to troubleshoot for fault codes. The HCE-DT app retrieves machine and engine data from a combined cloud-based platform to run a failure analysis in real-time. Combined with ECD, it increases first-visit fix rates.



Upgraded urea tank cover

The urea tank cover has been updated to a fully open type to make filling more convenient.



Mobile Fleet app

Hyundai's new Mobile Fleet app provides all the information you need to run your fleet efficiently and economically. Based on telematics, this advanced solution uses simple graphics and key performance data for smart fleet management.

200%
improved

Extended fuel filter lifetime

The fuel filter service interval has been increased from 500 hours to 1,000 hours. DPF cleaning is only required if alerted by a fault indication, eliminating the need for regular ash cleaning intervals.

HiMATE

Boost efficiency and performance

For maximum convenience and security, the HX235A LCR features Hyundai's exclusive Hi MATE remote fleet management system, which uses mobile data technology to provide the highest level of service and support. You can monitor your equipment wherever you are via a dedicated website or mobile app, with access to working parameters like total engine hours, machine utilisation, actual performed working hours and fuel consumption and machine location.

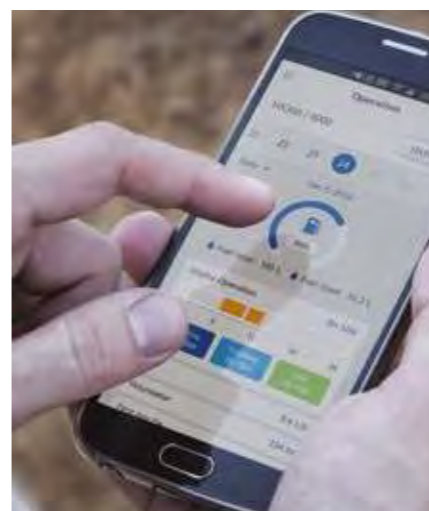

ECD (Engine Connected Diagnostics)

ECD provides troubleshooting advice as well as tailored servicing and parts support from Cummins Quick Serve. Service technicians are supported with remote diagnostics reports allowing them to prepare for site visits and bring the right tools.

We're all connected!



Just 5 minutes

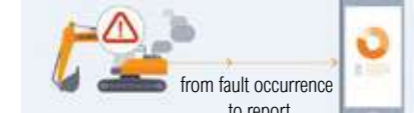

One-stop solution



Increase productivity

By providing information such as service hours, idle time and fuel consumption, Hi MATE saves you money and improves productivity. Service alerts enable better maintenance planning.



Monitor your machines

Hi MATE's real-time location information allows better, more convenient monitoring of your equipment. Just log onto the Hi MATE website or mobile app to see your machines at any time, from any location. Receive data online, by e-mail or directly on your mobile device.



Improve security

Protect your equipment from theft or unauthorised usage. Hi MATE's geofencing alerts notify you automatically when a machine leaves a predetermined zone.

Parts & Warranties

HYUNDAI GENUINE PARTS AND WARRANTIES: THE BEST WAY TO PROTECT YOUR INVESTMENT

Hyundai Genuine parts, accessories and warranty programmes are specially designed to keep your machine covered. They increase uptime and maintain the performance, comfort, and convenience that are built into your equipment.



A network you can rely on

Hyundai Construction Equipment Europe prioritises quick, reliable intervention to keep your equipment running reliably. In the 13000 m² warehouse, Hyundai covers over 96% of all Genuine Parts. With one of Europe's most advanced automated warehousing systems, we are able to maintain availability and efficient delivery of all our Genuine Parts. Moreover, we guarantee a 24-hour delivery service across our European dealer network.



Fuel filters

Hyundai fuel filters provide the right degree of filtration to keep your engine clean. They are designed to meet and exceed the engine manufacturer's prerequisites for water separation and dirt filtration, prolonging the life of your engine.



Hyundai Genuine parts

Hyundai Genuine parts have the same design as those installed when your machine left the factory. They are subjected to rigorous quality inspections and tests to make sure they meet Hyundai's strict requirements for quality and durability. As well as minimising downtime, this helps to ensure peak performance on every task.



Aftermarket kits

You can order Hyundai aftermarket kits via your dealer. This AAVM system for example, improves safety in and around your working environment at all times.



Hyundai warranties

Our warranties are also designed to give you the cover you need to build your business with confidence and peace of mind.

Standard warranties

We offer standard warranty coverages for all crawler excavators. Next to this standard coverage, optional and extended warranty periods are available, so you can benefit from full warranty coverage for longer, and even over the full lifetime of the machines. Please discuss the optimal solution for your needs with your local Hyundai dealer.

Extended warranties

Our extended warranties help you maintain full control over your operating costs. If you combine an extended warranty programme with a tailored maintenance contract, you can completely avoid unexpected costs.

Walk-around

HX235A LCR

Productivity & Efficiency

- High-performance, EGR-free engine **NEW**
- Eco Report **NEW**
- Electronic Pump Flow Control (EPFC) **NEW**
- Lifting mode **NEW**
- Fuel Rate Information
- Eco Gauge
- Automatic engine shutdown

Serviceability

- Engine Connected Diagnostics (ECD) **NEW**
- Hi MATE telematics system
- 2x longer-lasting fuel filter (1,000 hrs)
- Upgraded urea tank cover
- Mobile Fleet app
- Connected diagnostics



Durability

- FOPS/TOPS cabin
- Reinforced upper and lower structure
- Reinforced attachments
- Durable cooling module

Operator Comfort

- Key On Init Work Mode **NEW**
- New audio system **NEW**
- Wi-Fi Direct with smartphone (Miracast)
- Proportional auxiliary hydraulic system **OPTION**
- 2-way proportional RCV & pedal control selection **OPTION**
- Fine (cushion/free) swing Control **OPTION**
- 8" touchscreen monitor
- Owner Menu Editing (OME)
- Combination speed system

Safety

- Auto safety lock **NEW**
- Electronic swing parking brake **NEW**
- AAVM camera system **OPTION**
- Seatbelt warning alarm
- Wide steps

READY TO CHANGE YOUR WORLD

Hyundai's crawler excavators are designed to create better conditions for operators and deliver the ultimate ownership experience. Every detail is carefully fine-tuned to match your needs in the field, including better safety and comfort, higher productivity, maximum uptime and easy servicing. It's all part of the Hyundai Effect.

Explore the range at hyundai-ce.eu

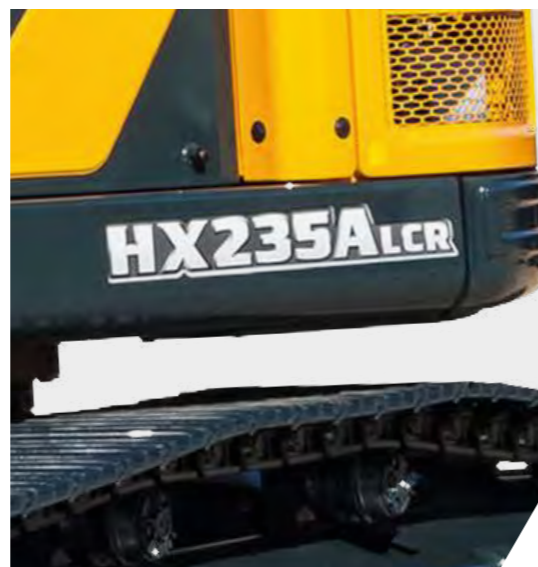

SPECIFICATIONS

ENGINE	
Maker / Model	CUMMINS / B6.7
Type	6 cylinder, water cooled, 4-cycle, turbocharged charge air cooled, direct injection, electronic controlled diesel engine
Gross Power	129 kW (173 hp) at 2,200 rpm
Net Power	127 kW (170 hp) at 2,200 rpm
Max. Power	145 kW (195 hp) at 2,000 rpm
Peak Torque	881 N . m (650 lb . ft) at 1,300 rpm
Displacement	6.7 l (409 cu in)

HYDRAULIC SYSTEM	
MAIN PUMP	
Type	Variable displacement tandem axis piston pumps
Max. flow	2 x 221 L/min (2 x 58.4 US gpm / 2 x 48.6 UK gpm)
Sub-pump for pilot circuit	Gear pump
Cross-sensing and fuel saving pump system.	

HYDRAULIC MOTORS	
Travel	Two speed axial pistons motor with brake valve and parking brake
Swing	Axial piston motor with automatic brake

RELIEF VALVE SETTING	
Implement circuits	350 kgf/cm ² (4,980 psi)
Travel	350 kgf/cm ² (4,980 psi)
Power boost (boom, arm, bucket)	380 kgf/cm ² (5,410 psi)
Swing circuit	285 kgf/cm ² (4,050 psi)
Pilot circuit	40 kgf/cm ² (570 psi)
Service valve	Installed

HYDRAULIC CYLINDERS			
No. of cylinder bore X stroke		Boom	2-120 X 1,290 mm
		Arm	1-140 X 1,510 mm
		Bucket	1-120 X 1,055 mm
	2-Piece Boom	1st	2-125 X 1,260 mm
		2nd	1-160 X 1,060 mm

* Hyundai Bio Hydraulic Oil (HBHO) available.

DRIVING AND BRAKING	
Drive method	Fully hydrostatic type
Drive motor	Axial piston motor, in-shoe design
Reduction system	Planetary reduction gear
Max. drawbar pull	22,200 kgf (48,943 lbf)
Max. travel speed (high/low)	5.6 km/hr (3.5 mph) / 3.2 km/hr (2 mph)
Gradeability 35° (70 %)	35° (70 %)
Parking brake	Multi wet disc

CONTROL	
Pilot pressure operated joysticks and pedals with detachable lever provide almost effortless and fatigueless operation.	
Pilot control	Two joysticks with one safety lever (LH): Swing and arm (RH): Boom and bucket (ISO)
Traveling and steering	Two levers with pedals
Engine throttle	Electric, Dial type

SWING SYSTEM	
Swing motor	Swing motor Fixed displacement axial piston motor
Swing reduction	Planetary gear reduction
Swing bearing lubrication	Grease-bathed
Swing brake	Multi wet disc
Swing speed	11.3 rpm

SERVICE CAPACITIES			
	liter	US gal	UK gal
Fuel tank	320.0	84.5	70.4
Engine coolant	40.0	10.6	8.8
Engine oil	23.1	6.1	5.1
Swing device	7.0	1.8	1.5
Final drive (each)	48.0	12.6	10.5
DEF / AdBlue R tank	48.0	12.6	10.5
Hydraulic system (including tank)	275.0	72.6	60.5
Hydraulic tank	160.0	42.3	35.2

UNDERCARRIAGE	
The X-leg type center frame is integrally welded with reinforced box-section track frames. The undercarriage includes lubricated rollers, idlers, track adjusters with shock absorbing springs and sprockets, and a track chain with double or triple grouser shoes.	
Center frame	X - leg type
Track frame	Pentagonal box type
No. of shoes on each side	49 EA
No. of carrier roller on each side	2 EA
No. of track roller on each side	9 EA
No. of rail guard on each side	2 EA

OPERATING WEIGHT (APPROXIMATE)			
Operating weight, including 5,680 mm (18' 8") boom, 2,920 mm (9' 7") arm, SAE heaped 0.80 m ³ (1.05 yd ³) bucket, lubricant, coolant, full fuel tank, full hydraulic tank, and all standard equipments.			
SHOES		OPERATING WEIGHT	GROUND PRESSURE
Type	Width mm (in)	kg (lb)	kgf/cm ² (psi)
Triple Grouser	600 (24")	24,000 (52,910)	0.51 (7.27)
	700 (28")	24,280 (53,530)	0.44 (6.30)
	800 (32")	24,560 (54,140)	0.39 (5.58)

AIR CONDITIONING SYSTEM	
The air condition system for the machine contains the fluorinated greenhouse gas with global warming potential of R134a. (Global Warming Potential : 1430) The system holds 0.75 kg refrigerant consisting of a CO ₂ equivalent 1.07 kg metric tonne. For more information, please refer to the manual.	

DIMENSIONS & WORKING RANGE

HX235A LCR MONO BOOM DIMENSIONS

5.68 m (18' 8") BOOM and 2.0 m (6' 7"), 2.4 m (7' 10"), 2.92 m (9' 7") ARM

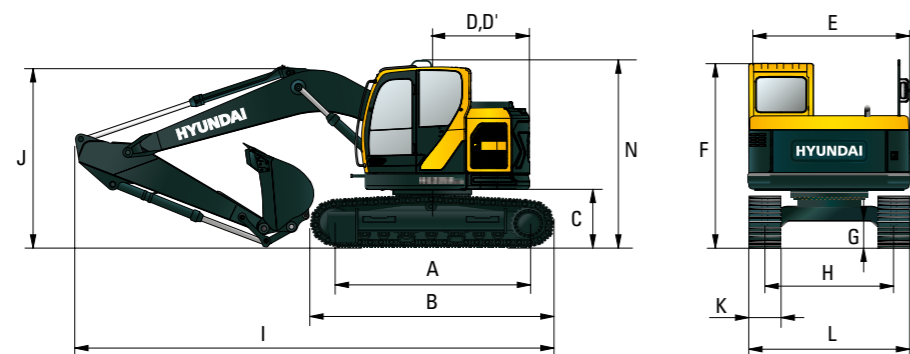

Unit : mm (ft-in)

A	Tumbler distance	3,650 (12' 0")
B	Overall length of crawler	4,446 (14' 7")
C	Ground clearance of counterweight	1,080 (3' 7")
D	Tail swing radius	1,780 (6' 04")
D'	Rear-end length	1,780 (6' 04")
E	Overall width of upperstructure	2,980 (9' 9")
F	Overall height of cab	3,100 (10' 2")
G	Min. ground clearance	470 (1' 65")
H	Track gauge	2,390 (7' 10")
I	Overall height of guardrail	3,290 (10' 10")

Boom Length		5,680 (18' 8")		
Arm Length		2,000 (6' 7")	2,400 (7' 10")	2,920 (9' 7")
I	Overall length	9,050 (29' 8")	8,950 (29' 4")	8,910 (29' 3")
J	Overall height of boom	3,240 (10' 8")	3,130 (10' 3")	3,040 (10' 0")
K	Track shoe width	600 (1' 12")	700 (2' 4")	800 (2' 7")
L	Overall width	2,990 (9' 10")	3,090 (10' 2")	3,190 (10' 6")

DIMENSIONS & WORKING RANGE

HX235A LCR MONO BOOM (DOZER TYPE) DIMENSIONS

5.68 m (18' 8") BOOM and 2.0 m (6' 7"), 2.4 m (7' 10"), 2.92 m (9' 7") ARM

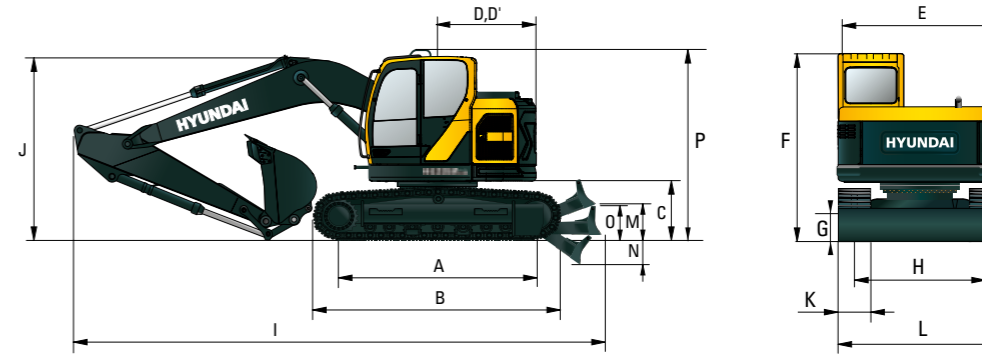

Unit : mm (ft-in)

A	Tumbler distance	3,650 (12' 0")
B	Overall length of crawler	4,404 (14' 6")
C	Ground clearance of counterweight	1,080 (3' 7")
D	Tail swing radius	1,780 (6' 04")
D'	Rear-end length	1,780 (6' 04")
E	Overall width of upperstructure	2,980 (9' 9")
F	Overall height of cab	3,100 (10' 2")
G	Min. ground clearance	470 (1' 65")
H	Track gauge	2,390 (7' 10")
M	Ground clearance of blade up	550 (1' 10")
N	Depth of blade down	410 (1' 4")
O	Height of blade	740 (2' 5")
P	Overall height of guardrail	3,290 (10' 10")

Boom Length		5,680 (18' 8")		
Arm Length		2,000 (6' 7")	2,400 (7' 10")	2,920 (9' 7")
I	Overall length	9,980 (32' 9")	9,890 (32' 5")	9,840 (32' 3")
J	Overall height of boom	3,240 (10' 8")	3,130 (10' 3")	3,040 (10' 0")
K	Track shoe width	600 (1' 12")	700 (2' 4")	800 (2' 7")
L	Overall width	2,990 (9' 10")	3,090 (10' 2")	3,190 (10' 6")

HX235A LCR MONO BOOM WORKING RANGE

Unit : mm (ft-in)

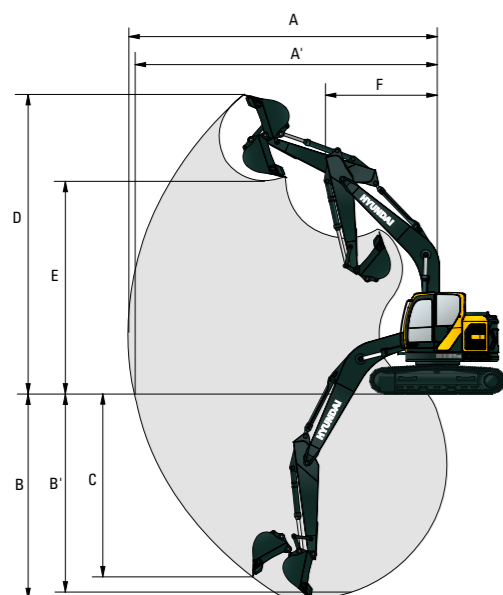

Boom Length		5,680 (18' 8")		
Arm Length		2,000 (6' 7")	2,400 (7' 10")	2,920 (9' 7")
A	Max. digging reach	9,040 (29' 8")	9,430 (30' 11")	9,910 (32' 6")
A'	Max. digging reach on ground	8,860 (29' 1")	9,260 (30' 5")	9,750 (32' 0")
B	Max. digging depth	5,750 (18' 10")	6,150 (20' 2")	6,670 (21' 11")
B'	Max. digging depth (8' level)	5,490 (18' 0")	5,940 (19' 6")	6,490 (21' 4")
C	Max. vertical wall digging depth	5,120 (16' 10")	5,570 (18' 3")	6,090 (20' 0")
D	Max. digging height	10,130 (33' 3")	10,460 (34' 4")	10,820 (35' 6")
E	Max. dumping height	7,220 (23' 8")	7,540 (24' 9")	7,900 (25' 11")
F	Min. swing radius	2,860 (9' 5")	2,550 (8' 4")	2,350 (7' 9")

HX235A LCR MONO BOOM (DOZER TYPE) WORKING RANGE

Unit : mm (ft-in)

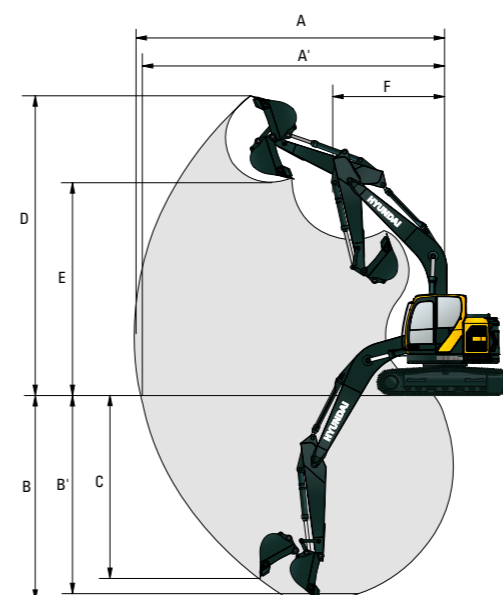

Boom Length		5,680 (18' 8")		
Arm Length		2,000 (6' 7")	2,400 (7' 10")	2,920 (9' 7")
A	Max. digging reach	9,040 (29' 8")	9,430 (30' 11")	9,910 (32' 6")
A'	Max. digging reach on ground	8,860 (29' 1")	9,260 (30' 5")	9,750 (32' 0")
B	Max. digging depth	5,750 (18' 10")	6,150 (20' 2")	6,670 (21' 11")
B'	Max. digging depth (8' level)	5,490 (18' 0")	5,940 (19' 6")	6,490 (21' 4")
C	Max. vertical wall digging depth	5,120 (16' 10")	5,570 (18' 3")	6,090 (20' 0")
D	Max. digging height	10,130 (33' 3")	10,460 (34' 4")	10,820 (35' 6")
E	Max. dumping height	7,220 (23' 8")	7,540 (24' 9")	7,900 (25' 11")
F	Min. swing radius	2,860 (9' 5")	2,550 (8' 4")	2,350 (7' 9")

DIMENSIONS & WORKING RANGE

HX235A LCR 2-PIECE BOOM DIMENSIONS

5,65 m (18' 6") 2-Piece Boom and 2.0 m (6' 7"), 2.4 m (7' 10"), 2.92 m (9' 7") Arm

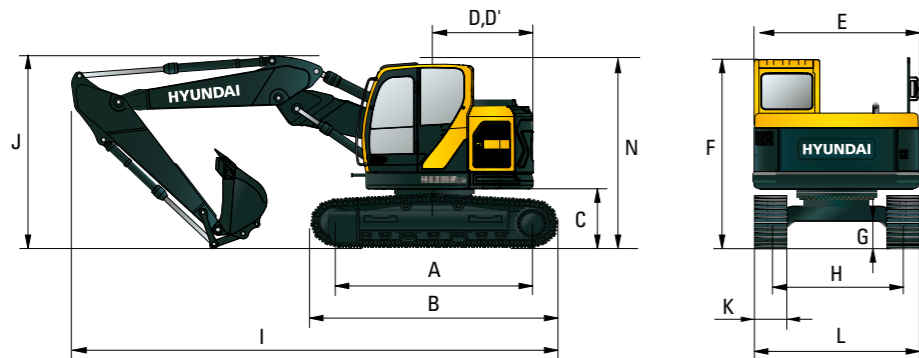

Unit : mm (ft-in)

A	Tumbler distance	3,650 (12' 0")
B	Overall length of crawler	4,406 (14' 7")
C	Ground clearance of counterweight	1,080 (3' 7")
D	Tail swing radius	1,780 (6' 04")
D'	Rear-end length	1,780 (6' 04")
E	Overall width of upperstructure	2,980 (9' 9")
F	Overall height of cab	3,100 (10' 2")
G	Min. ground clearance	470 (1' 65")
H	Track gauge	2,390 (7' 10")
N	Overall height of guardrail	3,290 (10' 10")

Boom Length		5,650 (18' 6") 2-Piece		
Arm Length		2,000 (6' 7")	2,400 (7' 10")	2,920 (9' 7")
I	Overall length	9,000 (29' 6")	8,910 (29' 3")	8,900 (29' 2")
J	Overall height of boom	3,050 (10' 0")	3,000 (9' 10")	2,990 (9' 10")
K	Track shoe width	600 (1' 12")	700 (2' 4")	800 (2' 7")
L	Overall width	2,990 (9' 10")	3,090 (10' 2")	3,190 (10' 6")

DIMENSIONS & WORKING RANGE

HX235A LCR 2-PIECE BOOM (DOZER TYPE) DIMENSIONS

5,65 m (18' 6") 2-Piece Boom and 2.0 m (6' 7"), 2.4 m (7' 10"), 2.92 m (9' 7") Arm

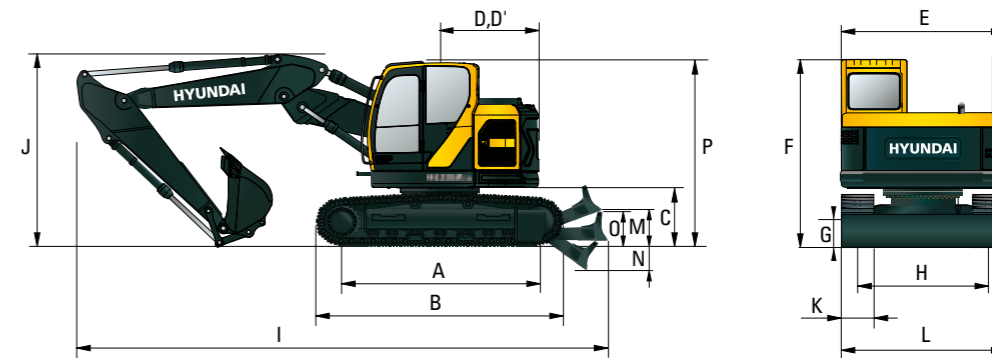

Unit : mm (ft-in)

A	Tumbler distance	3,650 (12' 0")
B	Overall length of crawler	4,404 (14' 6")
C	Ground clearance of counterweight	1,080 (3' 7")
D	Tail swing radius	1,780 (6' 04")
D'	Rear-end length	1,780 (6' 04")
E	Overall width of upperstructure	2,980 (9' 9")
F	Overall height of cab	3,100 (10' 2")
G	Min. ground clearance	470 (1' 65")
H	Track gauge	2,390 (7' 10")
M	Ground clearance of blade up	550 (1' 10")
N	Depth of blade down	410 (1' 4")
O	Height of blade	740 (2' 5")
P	Overall height of guardrail	3,290 (10' 10")

Boom Length		5,650 (18' 6") 2-Piece		
Arm Length		2,000 (6' 7")	2,400 (7' 10")	2,920 (9' 7")
I	Overall length	9,850 (32' 4")	9,760 (32' 0")	9,750 (32' 0")
J	Overall height of boom	3,050 (10' 0")	3,000 (9' 10")	2,990 (9' 10")
K	Track shoe width	600 (1' 12")	700 (2' 4")	800 (2' 7")
L	Overall width	2,990 (9' 10")	3,090 (10' 2")	3,190 (10' 6")

HX235A LCR 2-PIECE BOOM WORKING RANGE

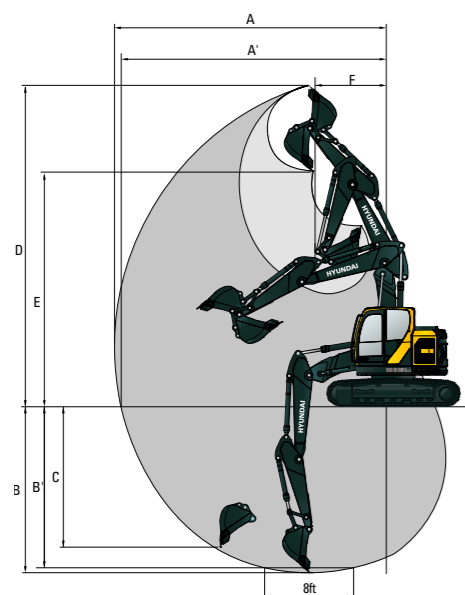

Unit : mm (ft-in)

Boom Length		5,650 (18' 6") 2-Piece		
Arm Length		2,000 (6' 7")	2,400 (7' 10")	2,920 (9' 7")
A	Max. digging reach	9,050 (29' 8")	9,460 (31' 0")	10,020 (32' 10")
A'	Max. digging reach on ground	8,880 (29' 2")	9,290 (30' 6")	9,860 (32' 4")
B	Max. digging depth	5,460 (17' 11")	5,860 (19' 3")	6,380 (20' 11")
B'	Max. digging depth (8' level)	5,340 (17' 6")	5,750 (18' 10")	6,270 (20' 7")
C	Max. vertical wall digging depth	4,530 (14' 10")	4,970 (16' 4")	5,520 (18' 1")
D	Max. digging height	10,600 (34' 9")	10,990 (36' 1")	11,470 (37' 8")
E	Max. dumping height	7,680 (25' 2")	8,090 (26' 7")	8,540 (28' 0")
F	Min. swing radius	2,130 (7' 0")	2,030 (6' 8")	2,000 (6' 7")

HX235A LCR 2-PIECE BOOM (DOZER TYPE) DIMENSIONS

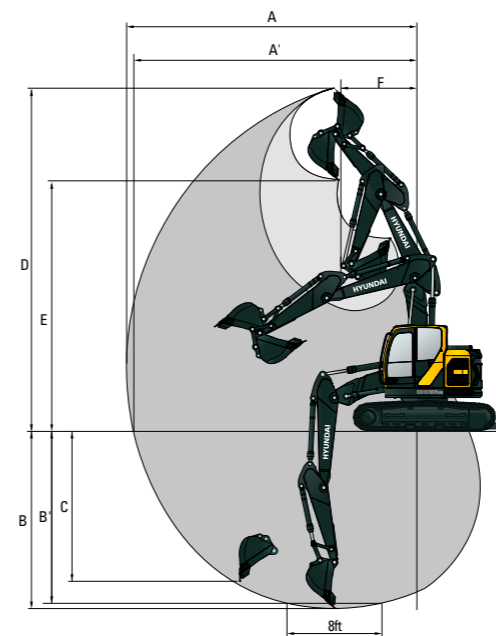

Unit : mm (ft-in)

Boom Length		5,650 (18' 6") 2-Piece		
Arm Length		2,000 (6' 7")	2,400 (7' 10")	2,920 (9' 7")
A	Max. digging reach	9,050 (29' 8")	9,460 (31' 0")	10,020 (32' 10")
A'	Max. digging reach on ground	8,880 (29' 2")	9,290 (30' 6")	9,860 (32' 4")
B	Max. digging depth	5,460 (17' 11")	5,860 (19' 3")	6,380 (20' 11")
B'	Max. digging depth (8' level)	5,340 (17' 6")	5,750 (18' 10")	6,270 (20' 7")
C	Max. vertical wall digging depth	4,530 (14' 10")	4,970 (16' 4")	5,520 (18' 1")
D	Max. digging height	10,600 (34' 9")	10,990 (36' 1")	11,470 (37' 8")
E	Max. dumping height	7,680 (25' 2")	8,090 (26' 7")	8,540 (28' 0")
F	Min. swing radius	2,130 (7' 0")	2,030 (6' 8")	2,000 (6' 7")

BUCKET SELECTION GUIDE & DIGGING FORCE

BUCKETS

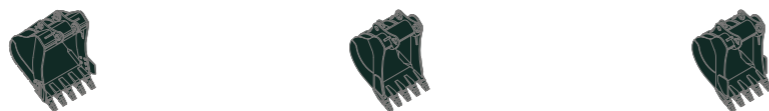

SAE heaped m ³ (yd ³)	0.80	◆ 0.90 (1.18)	◆ 0.85
	0.87		◆ 1.00
	0.92		◆ 1.15
	1.34		

Capacity m ³ (yd ³)		Width mm (in)		Weight kg (lb)	Recommendation mm (ft.in)					
SAE heaped	CECE heaped	Without side cutters	With side cutters		5,680 (18' 8") Mono Boom			5,650 (18' 6") 2-Piece Boom		
					2,000 (6' 7") Arm	2,400 (7' 10") Arm	2,920 (9' 7") Arm	2,000 (6' 7") Arm	2,400 (7' 10") Arm	2,920 (9' 7") Arm
0.80 (1.05)	0.70 (0.92)	1,000 (39")	1,120 (44")	700 (1,700)	●	●	●	●	●	●
0.87 (1.14)	0.75 (0.98)	1,090 (43")	1,210 (48")	805 (1,770)	●	●	●	●	●	●
0.92 (1.20)	0.80 (1.05)	1,150 (45")	1,270 (50")	820 (1,810)	●	●	○	●	●	○
1.34 (1.75)	1.15 (1.50)	1,550 (61")	1,670 (66")	990 (2,180)	■	■	▲	■	■	▲
◆ 0.90 (1.18)	0.80 (1.05)	1,095 (43")	-	880 (1,940)	●	●	○	●	●	○
◆ 0.85 (1.11)	1.00 (1.31)	1,410 (56")	-	860 (1,900)	●	●	●	●	●	●
◆ 1.00 (1.31)	0.92 (1.20)	1,290 (51")	-	945 (2,080)	●	○	○	●	●	○
◆ 1.15 (1.50)	0.75 (0.98)	1,140 (45")	-	1,030 (2,270)	○	■	■	○	■	■

- ◆ Heavy duty bucket
- Rock-Heavy duty bucket
- Slope finishing bucket
- Applicable for materials with density of 2,100 kgf/m³ (3,500 lbf/yd³) or less
- Applicable for materials with density of 1,800 kgf/m³ (3,000 lbf/yd³) or less
- Applicable for materials with density of 1,500 kgf/m³ (2,500 lbf/yd³) or less
- ▲ Applicable for materials with density of 1,200 kgf/m³ (2,000 lbf/yd³) or less

ATTACHMENT

Booms and arms are welded with a low-stress, full-box section design. 5.68 m (18'8") Mono, 5.65 m (18'6") 2 Piece Booms and 2.0 m (6'7"), 2.4 m (7'10"), 2.92 m (9'7") Arms are available.

DIGGING FORCE

Arm	Length	mm (ft.in)	2,000 (6' 7")			2,400 (7' 10")			2,920 (9' 7")			Remark
			kg (lb)	kN	kgf	kg (lb)	kN	kgf	kg (lb)	kN	kgf	
Bucket Digging Force	SAE	kN	133.4 [144.8]		133.4 [144.8]		133.4 [144.8]		133.4 [144.8]		[]: Power Boost	
		kgf	13,600 [14,770]		13,600 [14,770]		13,600 [14,770]		13,600 [14,770]			
		lbf	29,980 [32,550]		29,980 [32,550]		29,980 [32,550]		29,980 [32,550]			
	ISO	kN	152.0 [165.0]		152.0 [165.0]		152.0 [165.0]		152.0 [165.0]			
		kgf	15,500 [16,830]		15,500 [16,830]		15,500 [16,830]		15,500 [16,830]			
		lbf	34,170 [37,100]		34,170 [37,100]		34,170 [37,100]		34,170 [37,100]			
Arm Crowd Force	SAE	kN	144.2 [156.5]		119.6 [129.9]		102.0 [110.7]		102.0 [110.7]			
		kgf	14,700 [15,960]		12,200 [13,250]		10,400 [11,290]		10,400 [11,290]			
		lbf	32,410 [35,190]		26,900 [29,210]		22,930 [24,900]		22,930 [24,900]			
	ISO	kN	151.0 [164.0]		125.5 [136.3]		106.9 [116.1]		106.9 [116.1]			
		kgf	15,400 [16,720]		12,800 [13,900]		10,900 [11,830]		10,900 [11,830]			
		lbf	33,950 [36,860]		28,220 [30,640]		24,030 [26,090]		24,030 [26,090]			

Note: Arm weight includes bucket cylinder, linkage, and pin

STANDARD/OPTIONAL EQUIPMENT

ENGINE	STD
CUMMINS B6.7 Engine	●
HYDRAULIC SYSTEM	STD
INTELLIGENT POWER CONTROL (IPC)	
3-power mode, 2-work mode, user mode	●
Variable Power Control	●
Electrical Pump Flow Control (EPFC)	●
Attachment Mode Flow Control	●
Engine Auto Idle	●
Engine Auto Shutdown Control	●
Electronic Fan Control	●
Hyundai Bio Hydraulic Oil (HBHO)	●
CABIN & INTERIOR	STD
ISO STANDARD CABIN	
Rise-up type windshield wiper	●
Radio/USB player	●
Handsfree mobile phone system with USB	●
12 volt power outlet (24V DC to 12V DC converter)	●
Electric horn	●
All-weather steel cab with 360° visibility	●
Safety glass - Tempered glass	●
Safety glass - Tempered glass with front laminated glass	●
Sliding fold-in front window	●
Sliding side window (LH)	●
Lockable door	●
Storage compartment & Ashtray	●
Transparent cabin roof-cover	●
Sun visor	●
Door and cab locks, one key	●
Pilot-operated slidable joystick	●
Console box height adjust system	●
AUTOMATIC CLIMATE CONTROL	
Air conditioner & heater	●
Defroster	●
Starting aid (air grid heater) for cold weather	●
CENTRALIZED MONITORING	
8" LCD display	●
LED room lamp	●
Engine speed or trip meter/accel.	●
Engine coolant temperature gauge	●
Max power	●
Low speed/High speed	●
Auto idle	●
Overload warning with alarm	●
Check engine	●
Air cleaner clogging	●
Indicators	●
ECO gauges	●
Fuel level gauge	●
Hyd. oil temperature gauge	●
Fuel warmer	●
Warnings	●
Communication error	●
Low battery	●
Clock	●
Cabin lights	●
Cabin front window rain guard	●
Cabin roof-plexi type	●
SEAT	
Adjustable air suspension seat with heater	●
Mechanical suspension seat with heater	●
CABIN FOPS (ISO 10262) LEVEL 2	
FOPS (Falling Object Protective Structure) ISO 10262 Level 2	●
CABIN ROPS (ISO 12117-2)	
ROPS (Roll Over Protective Structure)	●

SAFETY	STD
Lifting Mode	●
Battery master switch	●
Rearview camera	●
AAVM (Advanced Around View Monitoring)	●
Four front working lights (2 boom mounted, 2 front frame mounted)	●
Travel alarm	●
Rear work lamp (Halogen or LED)	●
Beacon lamp (Halogen or LED)	●
Electronic swing parking brake control	●
Boom holding system	●
Arm holding system	●
Safety lock valve for boom cylinder with overload warning device	●
Safety lock valve for arm cylinder	●
Swing Lock System	●
Two outside rearview mirrors	●
OTHER	STD
BOOMS	
5.68 m mono, 18' 8"	●
5.65 m 2-piece, 18' 6"	●
ARMS	
2.0 m, 6' 7"	●
2.4 m, 7' 10"	●
2.92 m, 9' 7"	●
Removable clean-out dust net for cooler	●
Removable reservoir tank	●
Fuel warmer	●
Self-diagnostics system	●
Hi MATE (Remote Management System) 5 years	●
Batteries (2 x 12V x 100 AH)	●
Fuel filler pump with auto stop function (50 L/min)	●
Single-acting piping kit (breaker, etc.)	●
Double-acting piping kit (clamshell, etc.)	●
Rotating Piping Kit	●
Air Compressor	●
Engine coolant heater	●
LED lamp	●
Smart button key	●
Electrical proportional Switch on RCV	●
Quick coupler piping	●
Quick coupler	●
Engcon Tiltrotator	●
One Pedal Straight Travel System	●
Accumulator for lowering work equipment	●
Pattern change valve (2 patterns)	●
Fine Swing Control System	●
Tool kit	●
UNDERCARRIAGE	STD
Lower frame under cover (Additional)	●
Lower frame under cover (Normal)	●
TRACK SHOES	
Triple grouser shoes 600 mm (1' 12")	●
Triple grouser shoes 700 mm (2' 4")	●
Triple grouser shoes 800 mm (2' 7")	●
Track rail guard	●
Dozer blade	●

- * Standard and optional equipment may vary. Contact your Hyundai dealer for more information. The machine may vary according to International standards.
- * The photos may include attachments and optional equipment that are not available in your area.
- * Materials and specifications are subject to change without advance notice.
- * All imperial measurements rounded off to the nearest pound or inch.



Specifications and design are subject to change without notice. Pictures of Hyundai Construction Equipment Europe products may show other than standard equipment.

Hyundai Construction Equipment Europe nv.
Hyundailaan 4, 3980 Tessenderlo, Belgium.
Tel: (+32) 14-56-2200 Fax: (+32) 14-59-3405

EN-2020-08 Rev 0

Ready to experience the Hyundai Effect?

Contact your Hyundai dealer.
hyundai-ce.eu/en/dealer-locator