

Engine output: petrol 8.4 PS / diesel 9.4 PS

Machine weight: from 540 kg to 740 kg

Machine payload: from 550 kg to 700 kg

For Earth, For Life

Kubota

# KC70-4 / KC70-4 P

## KUBOTA TRACKED DUMPER



COMPACT, POWERFUL AND DESIGNED FOR OPTIMUM COMFORT,  
THE NEW KUBOTA KC70-4 SAVES YOU TIME AND TROUBLE.  
10 VERSIONS ARE AVAILABLE (H/HV/VHD/SL/VSL),  
POWERED BY DIESEL AND PETROL ENGINE.

### Unloading operation



### Compact Design



With a minimum overall width of only 758 mm (for all versions) the KC70-4 efficiently transports material through gates and doorways, between houses, buildings and many other narrow spaces. This makes it the perfect mini-dumper for renovations and urban areas.

Unloading operation is fast and easy. The profile of the skip has been designed to ensure a quick discharge of the material. With a dumping angle of 88° (85° for HD/VHD versions), all materials exit easily from the skip in any work situation.

### Maintenance (*diesel version*)



### Maintenance (*petrol version*)



A large opening bonnet gives good access to the main areas for daily maintenance: fuel tank, air filter, engine oil level, battery, and battery isolator switch (when present) are easily reachable.

## 2 clean and environmentally friendly engines available



Tough and reliable, the air and oil cooled **KUBOTA diesel** engine delivers high torque, enhanced power and optimum fuel efficiency to minimize operating costs. It also features cleaner emissions and quieter operation, which means it has lower impact on the environment.



Our KC70-4 P with the **petrol engine** gives you power combined with quiet running. Lower fuel consumption, less emissions and better features. KUBOTA mini-dumper KC70-4 P series with Honda's GX270 engine will give you exceptional performance.

## Easy manual starting



All diesel versions as well as the HD and VHD petrol engine versions, have electric starting. All other petrol versions have a heavy-duty recoil starter, which must be operated from the driving position, in combination with the automatic mechanical de-compression system ensure you easy manual starting in all conditions.

## Safety stickers



Easily visible from the operator driving position. The safety stickers give quick and easy understanding of the machines operations. This increases security and productivity. Even an occasional operator immediately understands how to use the machine.

## Double cylinder (for versions with variable track)



This type of assembly structure reduces the minimum machine width to 758 mm (as standard versions) or can increase width to 1058 mm for extra stability.

## Document holder



Waterproof document holder for user manuals protected in the locked engine compartment. This allows the operator to have the machine's documents always available.

# KUBOTA TRACKED DUMPER

## KC70 H/HV-4

### Transmission system



The KC70-4 crawler dumpers are equipped with an hydraulic transmission. This advanced transmission offers smooth control, the operator can select the speed best suited for the terrain, and can easily shift from 3.3 km/h high speed on flat surfaces, to 2.2 km/h low speed for rougher terrain. This system helps make working more efficient and productive, reducing maintenance and also fuel consumption.

### Foldable foot plate



The KC70-4 features a foldable foot plate. When the plate is down, the operator can safely stand on it to operate the machine. When the plate is folded up, the overall length is reduced by 214 mm in order to gain space for transport or storage. The standing operation position makes it easier when getting on and off the machine.

### Performance

With a maximum loading capacity of 700 kg (550 kg for HD versions) and a heaped volume of 0.34 m<sup>3</sup> (0.29 m<sup>3</sup> for HD versions), the KC70-4 can transport material inside and outside buildings where space to maneuver is limited. The KC70-4 can easily avoid obstacles with a rear angle of 26° and a ground clearance up to 202 mm.

### Grease tension system and short pitch track



The rubber crawler is tensioned by a grease cylinder. This feature allows cushioning when foreign materials are going into the crawler. In addition, the short pitch track offers smooth drive for higher comfort for the operator.

### Comfortable & Easy Operation



All levers and controls are easy to reach and operate. A grab handle bar secures the operator during operation.

### Variable undercarriage (for KC70HV-4 version)

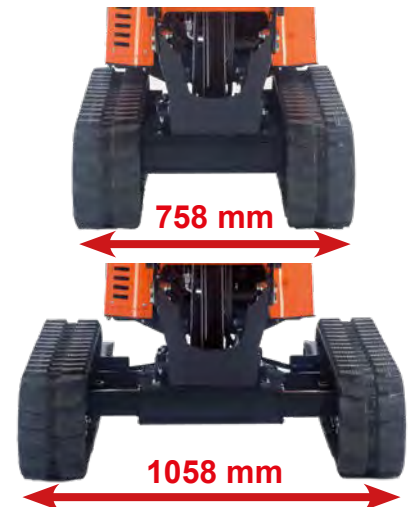

The variable undercarriage extends the overall width from 758 mm to 1058 mm. At minimum width, the KC70-4 can easily go through a standard door. At maximum width, the KC70-4 offers great stability in all conditions.



# KUBOTA TRACKED DUMPER KC70SL/VSL-4

## Hydraulic oil cooler (for diesel version)



The oil cooler is present only in diesel version (KC70SL/VSL-4). This makes them suitable for the toughest applications.

## Strong self-loading structure



## Hydraulic cylinders structure



The loading shovel is activated by two hydraulic cylinders located under the skip. Due to their position, they are well protected and they ensure a good lifting capacity.

## Control panel

All the levers are well protected by a bar which is used as well to hold on the machine. The levers are designed for easy grip and activation in all job situations.



## Self-loading shovel operation



The models KC70SL-4 and KC70VSL-4 are crawler dumpers featuring a self-loading shovel. This device is very useful when you need to remove loose material (such as sand or gravel) or to clear demolition rubble. The minimum width of 758 mm allows easy access inside buildings. On the VSL version, the variable undercarriage insures good stability regardless of ground condition. The loading capacity of 700 kg makes the KC70-4 SL/VSL the ideal work mate for moving material on the job site.

# KUBOTA TRACKED DUMPER KC70HD / VHD-4

## Truck easy loading operation



Thanks to its high dump function, the KC70HD/VHD-4 can empty its load up to 1,43m high (pin height). In addition, the dumping reach of 447mm allows easy discharge of the load from the skip, whilst leaving good clearance to the truck edge.



## Convenient width



Like the other models of the product family, the Kubota KC70HD/VHD-4 has been designed to work in confined area. The variable undercarriage version allows it to be driven through narrow spaces when minimum width is set (758mm overall width) and insure excellent stability when the undercarriage is extended to the maximum position (1058mm).

## Safety, tilt angle sensor



A warning buzzer turns on when the skip is at a certain level if the slope angle is more than 8°. A sensor located in the engine compartment, detects the angle of the frame. A micro-switch located on the lifting arm detects the position of the skip.

## Vertical lift

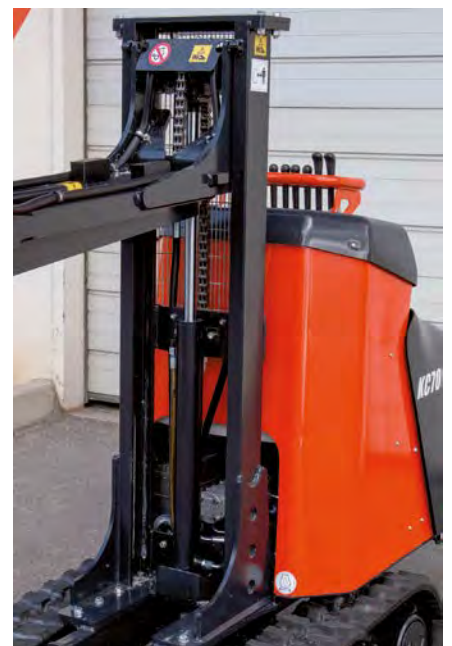

Due to the telescopic mast, the Kubota KC70VHD-4 guarantees maximum robustness and durability over time.

## Battery switch



For all diesel models. For petrol, only on HD and VHD versions.

## Stability alarm (only for HD and VHD versions)

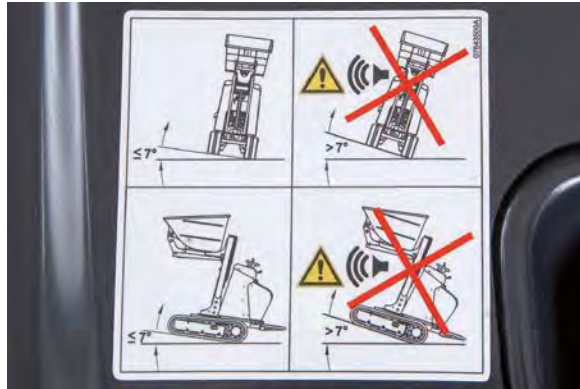

If the machine is in a slope (on the two axes) above 8°, and the skip is raised, an alarm warns of a hazard situation.

## Fuel tank tap



The fuel tank is fitted with a tap. If needed, the starter choke can be operated manually (petrol version).

## High tip discharges in full safety conditions.



The telescopic lifting system of HD and VHD versions guarantees maximum stability in the unloading phases.

## Easy refueling (for petrol version)



The console of petrol version can be opened for easily refueling of tank. In the diesel version, the operation is equally easy to accomplish.

## Control panel



A holding bar protect the control levers. All the control levers are easy to reach and activate. The machines functions are easy and accurate to operate.

## SPECIFICATIONS

Model		KC70H-4	KC70HV-4	KC70SL-4	KC70VSL-4	KC70VHD-4
Engine	Make	Kubota				
	Model	OC95				
	Output kW (PS) / rpm	7.1 (9.4) / 3500				
	Displacement cc	416				
	Cooling system	Air and oil cooled				
Service weight	kg	580	660	655	735	740
Max. loading capacity	kg	700				550
Skip tipping system		Hydraulic				
Dumping direction		Front				
Dumping height	mm	450		431	431	1355
Transmission	Type	Hydraulic				
	Hydraulic pump	2 gear type pumps				
	Flow (for each pump) <i>ℓ</i> /min	2 x 14.2				
	Hydraulic motors	Orbital motor				
	Max. pressure bar	165				
	Main valve	4 sections	5 sections	5 sections	6 sections	6 sections
Dimensions	Overall length mm	1860 / 2074		1892 / 2106		2010 / 2224
	Overall height mm	1300		1318		1625
	Overall width mm	758	758 ~ 1058	758	758 ~ 1058	
Internal skip dimensions	Length mm	1030		1071		943
	Width mm	686		628		677
	Height mm	615		641		559
	Dumping angle deg			88		85
	Heaped volume m <sup>3</sup>			0.34		0.29
	Level volume m <sup>3</sup>			0.28		0.24
Undercarriage	Ground clearance mm	202	127	202	127	
	Tumbler distance mm			894		
	Rubber shoe width mm			180		
	Track roller			3		
Travelling speed (Forward / Reverse)	1st speed km/h			0 ~ 2.2		
	2nd speed km/h			0 ~ 3.3		
	Max. grade ability	Front 15° / Side 20°		15°		Skip down 15° / Skip up 8°
Fuel tank capacity	<i>ℓ</i>			5.5		
Hydraulic oil tank capacity	<i>ℓ</i>			27		
Noise level	LpA dB (A)			92		
	LwA dB (A)			101		
Vibration*	Hand arm system m/s <sup>2</sup>			2.14		
	Whole body m/s <sup>2</sup>			0.61		

The data have been measured on the standard version. Specifications are subject to change without notice.

\* These values are measured under specific conditions at maximum engine speed and can deviate, depending on the operating situation.





## SPECIFICATIONS

Model		KC70H-4 P	KC70HV-4 P	KC70SL-4 P	KC70HD-4 P	KC70VHD-4 P
Engine	Make	Honda				
	Model	GX270				
	Output kW (PS) / rpm	6.3 (8.4) / 3600				
	Displacement cc	270				
	Cooling system	Air cooled				
Service weight	kg	540	620	600	620	700
Max. loading capacity	kg	700			550	
Skip tipping system		Hydraulic				
Dumping direction		Front				
Dumping height	mm	460		431	1355	
Transmission	Type	Hydraulic				
	Hydraulic pump	2 gear type pumps				
	Flow (for each pump) ℓ/min	2 x 14.2				
	Hydraulic motors	Orbital motor				
	Max. pressure bar	165				
	Main valve	4 sections	5 sections	5 sections	5 sections	6 sections
Dimensions	Overall length	mm		1860 / 2074	1892 / 2106	2010 / 2224
	Overall height	mm		1300	1318	1625
	Overall width	mm	758	758 ~ 1058	758	758 ~ 1058
Internal skip dimensions	Length	mm		1030	1070	943
	Width	mm		686	628	677
	Height	mm		615	641	559
	Dumping angle	deg		88		85
	Heaped volume	m <sup>3</sup>		0.34		0.29
	Level volume	m <sup>3</sup>		0.28		0.24
Undercarriage	Ground clearance	mm	202	127	202	127
	Tumbler distance	mm	894			
	Rubber shoe width	mm	180			
	Track roller		3			
Travelling speed (Forward / Reverse)	1st speed	km/h	0 ~ 2.2			
	2nd speed	km/h	0 ~ 3.3			
	Max. grade ability		15°		Skip down 15° / Skip up 8°	
Fuel tank capacity	ℓ	5.3				
Hydraulic oil tank capacity	ℓ	27				
Noise level	LpA	dB (A)		84		
	LwA	dB (A)		99		
Vibration*	Hand arm system	m/s <sup>2</sup>	2.30	2.21	2.18	
	Whole body	m/s <sup>2</sup>	0.60	0.67	0.65	

The data have been measured on the standard version. Specifications are subject to change without notice.

\* These values are measured under specific conditions at maximum engine speed and can deviate, depending on the operating situation.

### Available models and versions

VERSIONS	FEATURES	DIESEL ENGINE	PETROL ENGINE
H	Regular skip Fixed undercarriage	●	●
HV	Regular skip Extendable undercarriage	●	●
HD	High dump skip Fixed undercarriage		●
VHD	High dump skip Extendable undercarriage	●	●
SL	Regular skip Fixed undercarriage Self-loading	●	●
VSL	Regular skip Extendable undercarriage Self-loading	●	



# DIMENSIONS

**KC70H/HV-4**  
**KC70H/HV-4 P**

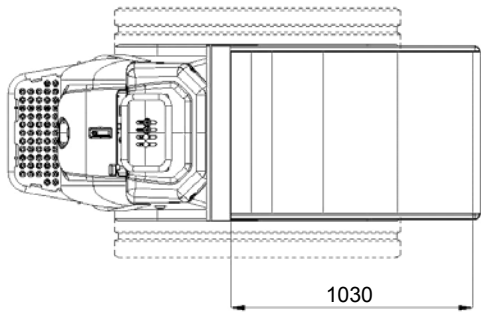
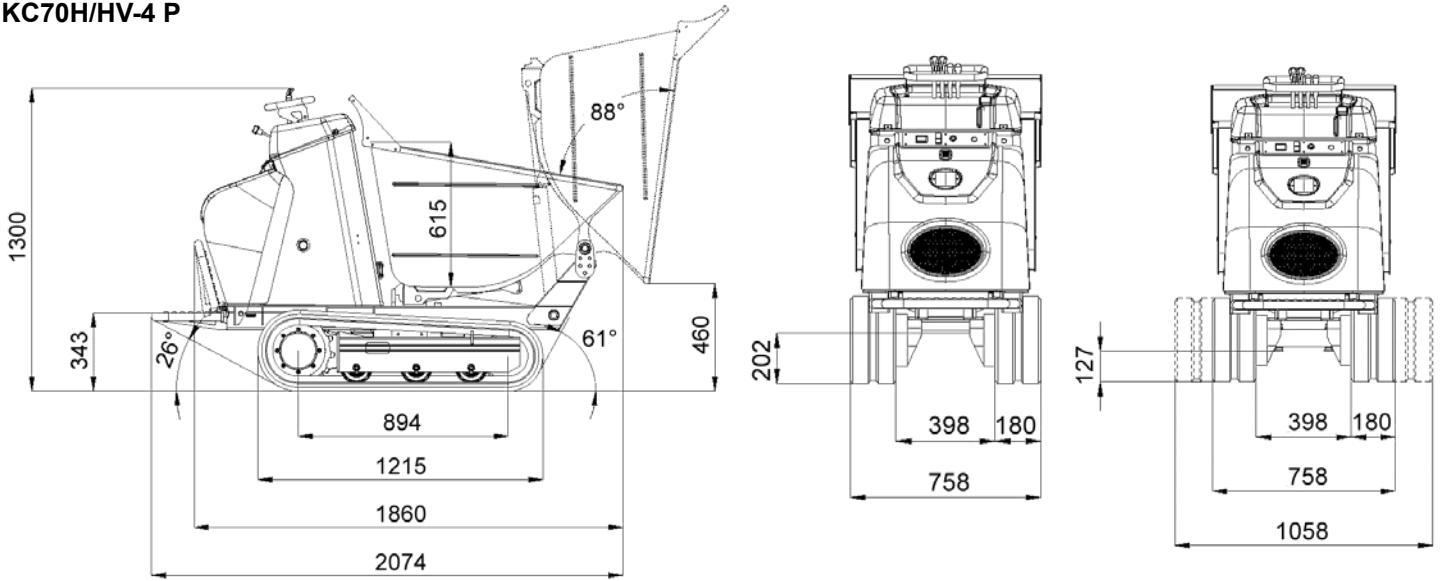

**KC70SL/VSL-4**  
**KC70SL-4 P**

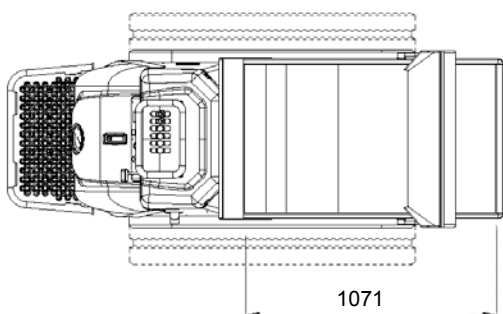
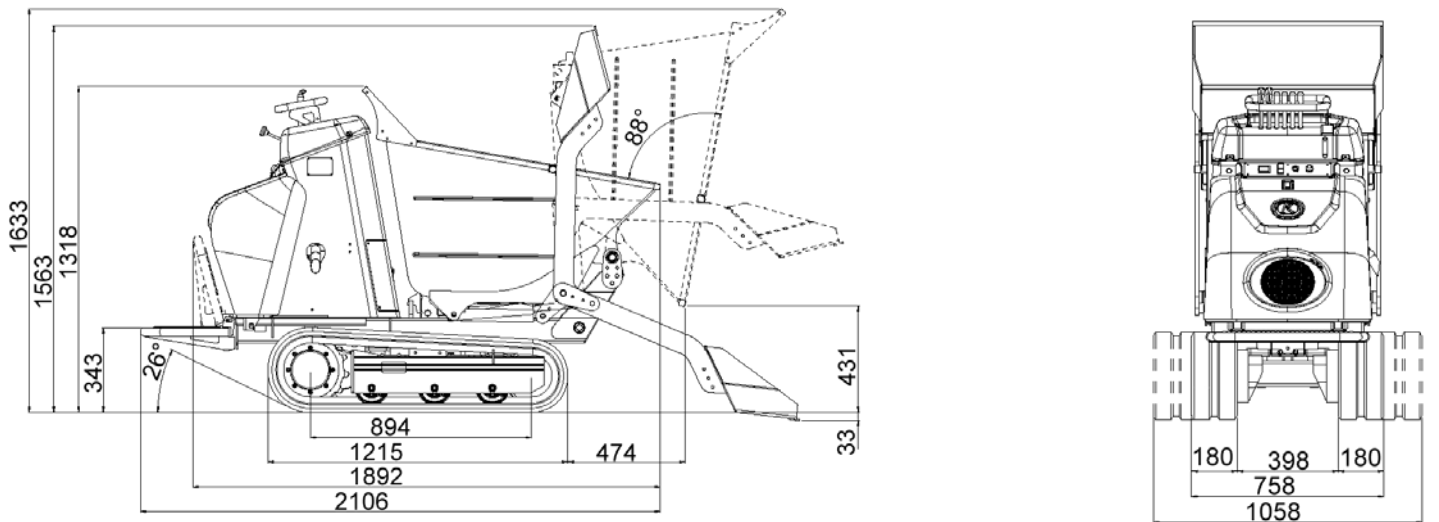

# DIMENSIONS

KC70VHD-4  
KC70HD/VHD-4 P

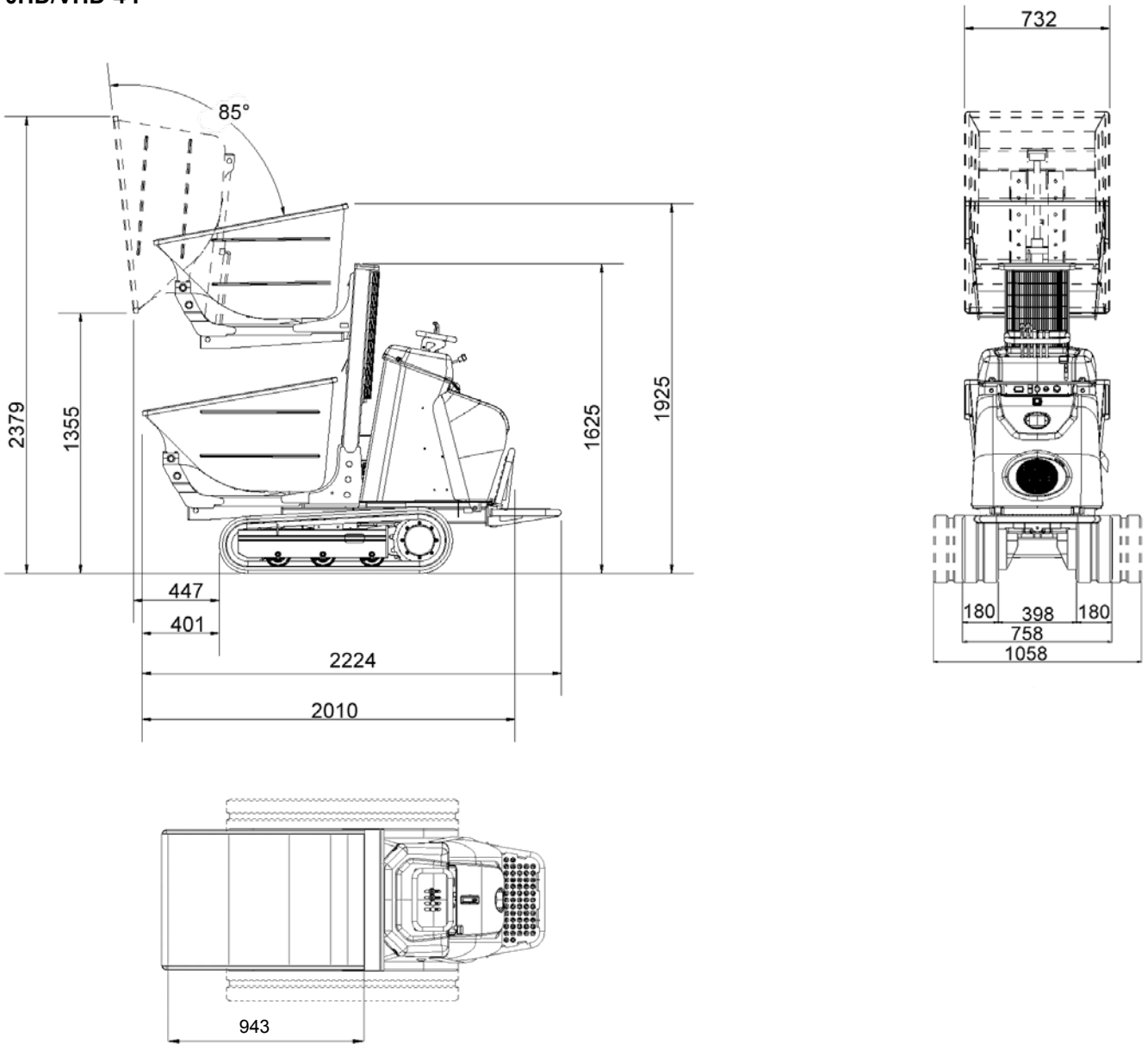

★ All image's shown are for brochure purposes only.  
When operating the tracked dumper, always wear proper PPE clothing and equipment in accordance to local legal and safety regulations.

**KUBOTA U.K. LTD**

Dormer Road, Thame, Oxfordshire  
OX93UN, U.K.

Phone: (44) 01 844-268140

Fax: (44) 01 844-216685

<http://www.kubota-eu.com>