

ELECTRIC TRACKED  
DUMPERS

KC70H-4e  
KC70VSL-4e



Battery (V / Ah):  
**48 / 120**

Machine weight (kg):  
**KC70H-4e : 645**  
**KC70VSL-4e : 740**

Payload (kg):  
**700**

# BATTERY / MOTORS

The KC70H-4e (front tip skip) and KC70VSL-4e (front tip skip, variable chassis and self loading device) are the first two electric machines of the Kubota range. They are based on the diesel and petrol versions with similar performances but integrate a battery instead of the engine in order to adapt to the on-going needs for machines without CO<sub>2</sub> emissions and and less noisy.

## BATTERY

It has been developed thanks to the LiMnCo technology (lithium / manganese / cobalt). It works with a nominal voltage of 48V DC (direct current), which means the machines belong to the extra low voltage range. Designed to last 3000 charging cycles, it will not be necessary to replace the battery during the life of the machine. A Heating device is integrated in order to be able to recharge with cold temperatures outside.



**A. Battery**  
**B. Charger**

**C. Inverters**  
**D. Document box**

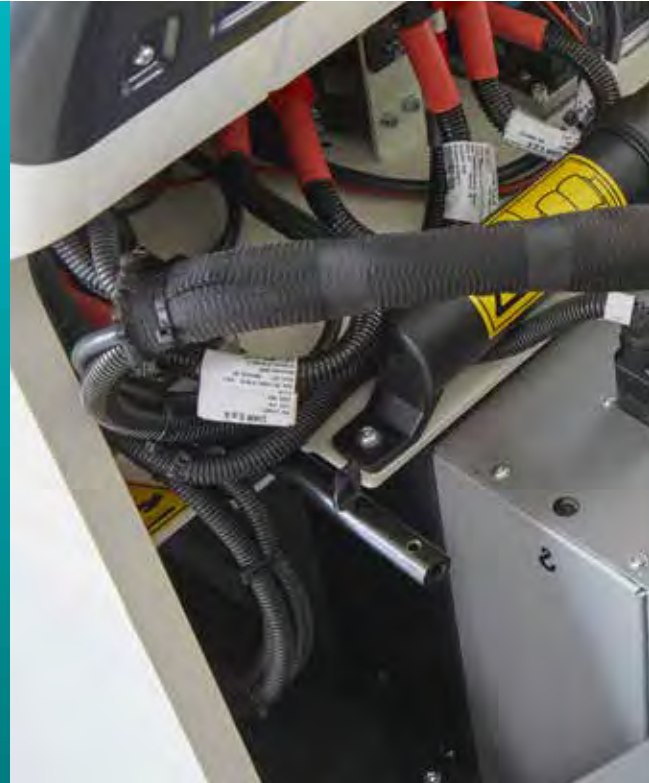

## MOTORS

On both models, the travel motors are electric and not hydraulic anymore. It allows for better efficiency and a better working time. They have been developed thanks to the IPM technology (interior permanent magnet) and work with a tension of 48V and an intensity of 120Ah (AC – alternative current). They are IP67, which means they can be underwater without any risk. It is entirely possible to work in very humid conditions.





## **BATTERY:**

**48V / 120 Ah**

## **CHARGER**

The machines are always equipped with a charger. To use it, you need to unplug the battery from the rest of the machine, plug the charger to the machine and then link it the electricity network (impossible to charge the machine while it works). It is possible to charge the machine with tensions between 80V to 240V / 3kW (the battery will adjust itself). With a tension of 220V, it will take 3 hours to completely charge the battery, and 1 hour and a half to gain 80% of the total charge. Finally, the charger can be removed. The charger can also be removed for use on another machine by simply unscrewing 2 screws.



## **ELECTRIC TRACKED DUMPERS**

**KC70H-4e**

**KC70VSL-4e**



# FEATURES

The KC70H-4e and KC70VSL-4e offer strong performances during the life of the machine. Unlike the electric travel motors, the control of the skip (KC70H-4e & KC70VSL-4e), of the self loading device and the extension of the tracks (only KC70VSL-4e) is done hydraulically. A pump and valve block are present inside the machines.

## SKIP

Skips of our tracked dumpers are well known for their durability and their loading volume. The design comes from our long experience into that type of machine.



**Skip capacity: 0,28 m<sup>3</sup>**  
**Heaped capacity: 0,34 m<sup>3</sup>**  
**Payload: 700 kg**

## SELF LOADING DEVICE

The KC70VSL-4e has a self loading device in order to have more versatility and more autonomy on the jobsite. No need for another machine to load the dumper.



## WORKING WIDTH

Our two machines allow to work on very narrow jobsites, to go through doors to pick up material and then transport this material. This can avoid the need for conveyor systems on site.

## KC70VSL-4e



758 mm



1058 mm



## VARIABLE CHASSIS

The VSL model is equipped with a variable chassis to adapt itself to the different conditions, retracted tracks to enter inside buildings (758 mm) or extended for more stability (1058 mm).

## KC70H-4e

The width of the H model is even narrower with 750 mm.

# DASHBOARD

The dashboard was developed with the operators comfort and safety in mind. The operator can hold the orange support bar with one hand whilst moving the machine with the other hand.

## SENSOR

The dead mans sensor cuts the power to the machine as soon as the operators hand is lifted.



## SCREEN

The central screen indicate the level of the battery, machine hours and some additional information on the status of the machine.



- A.** Support handle
- B.** Horn
- C.** Speed Low/high
- D.** Self loading device (VSL model)
- E.** Control of the skip
- F.** Variable châssis (VSL model)
- G.** Screen
- H.** Command to move the machine with dead man sensor integrated

★ All images shown are for brochure purposes only.  
When operating the electric tracked dumper, wear clothing and equipment in accordance to local legal and safety regulations.

### Kubota Genuine and Approved Parts

for maximum performance, durability and safety



# Dimensions and Performance

Model		KC70H-4e	KC70VSL-4e
<b>Dimensions and weight</b>			
Max length (transport layout)	mm	1934	1966
Max width	mm	750	758 / 1058
Machine height	mm	1358	
Max unloading height	mm	450	419
Machine weight*	kg	729	815
<b>Performance</b>			
Max Drive speed	km/h	2 / 4	
Max gradeability	°	15	
Skip capacity	m <sup>3</sup>	0,28	
Heaped capacity	m <sup>3</sup>	0,34	
Payload	kg	700	
<b>Undercarriage</b>			
Crawler width	mm	180	
Bottom rollers		3	
Idler		Spring-release with greased tensioner	
Brake		Negative, integrated in motors	

\*With a 75 kg operator.

## Battery

Model		KC70H-4e	KC70VSL-4e
Lithium-ion Battery	V	48	
	Ah	120	
Charger	kW	3	
	V	80-240	
Charging time for 100%	min	180	
Charging time for 80%	min	90	

## Electric motors

Model		KC70H-4e	KC70VSL-4e
Number		2	
Type	V AC	48	
Technology		IPM (Interior permanent magnet)	
Protection		IP67	

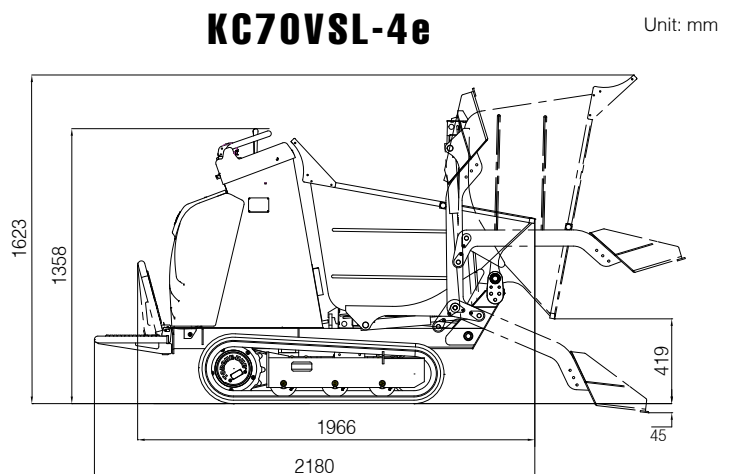
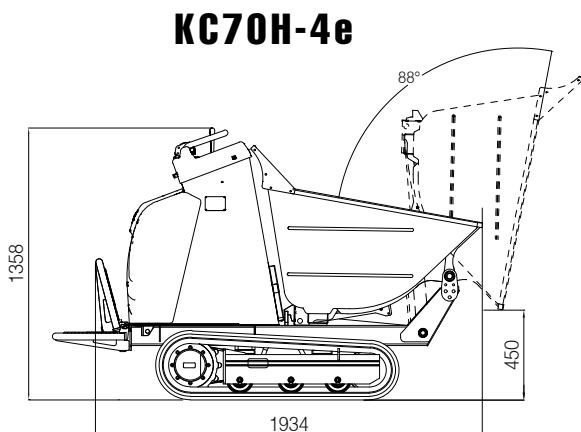

Unit: mm



**KUBOTA EUROPE S.A.S.**

19, rue Jules Vercaux  
Zone Industrielle - CS50088  
95101 Argenteuil Cedex France  
Téléphone : (33) 01 34 26 34 34  
Télécopieur : (33) 01 34 26 34 99



<https://www.kubota-eu.com>