

COMPACT EXCAVATOR

R18-9AK



READY TO CHANGE YOUR WORLD

The R18-9AK Compact Excavator is making environmental care a priority: a fresh generation of construction equipment that complies with the European Stage V emission levels. But it goes further than that! While fulfilling regulatory demands, Hyundai aimed for a higher level of customer satisfaction with excellent performance and more operator convenience.

From its compact and robust exterior design to its performance features, the R18-9AK opens up a world of new possibilities where tiny efforts move mountains. It's time to experience the Hyundai Effect!

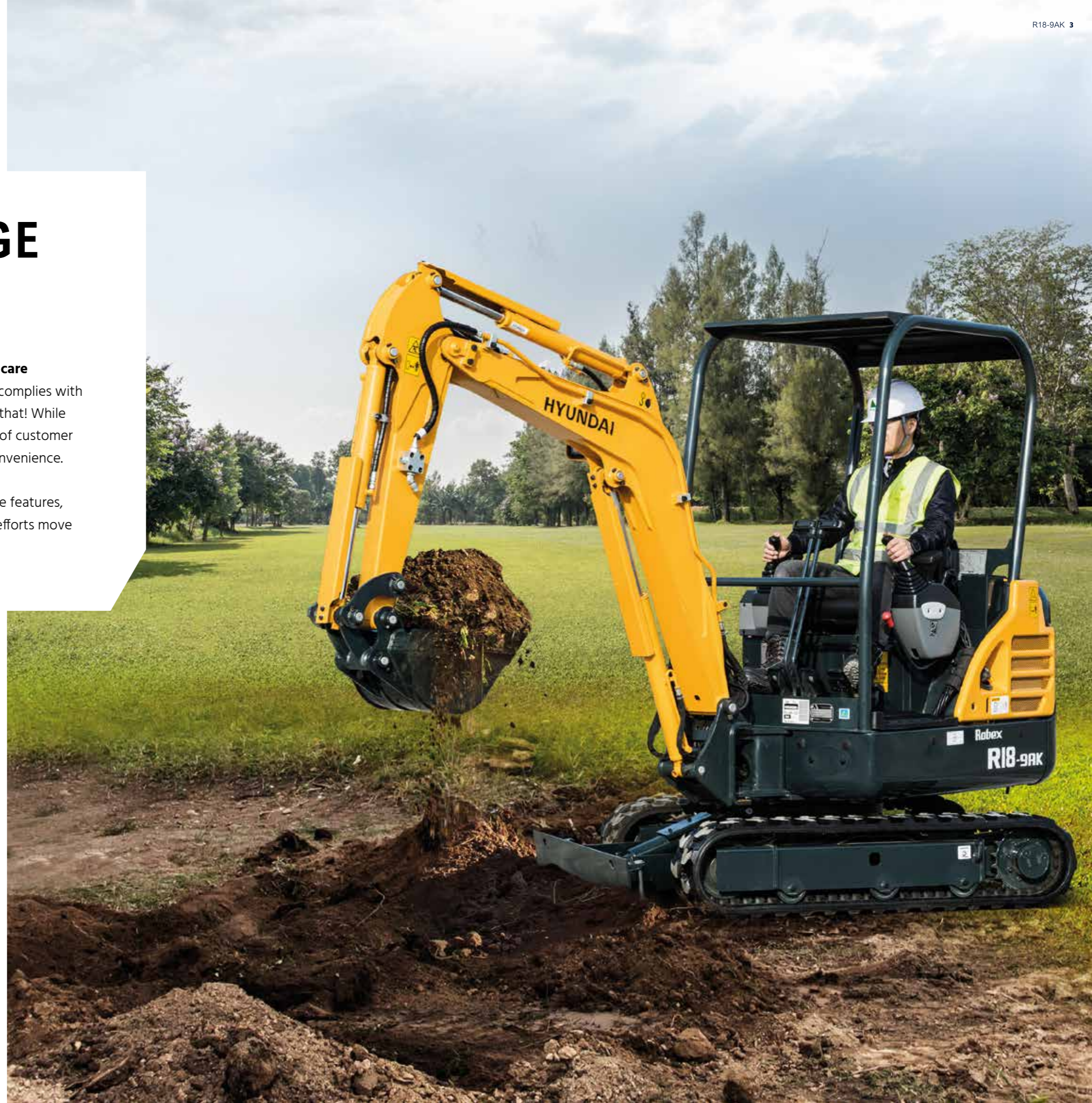

Productivity & Efficiency

ENVIRONMENTALLY FRIENDLY POWER TO BOOST YOUR PRODUCTIVITY

The R18-9AK is powered by a robust Stage V-certified Kubota D902 engine that has been optimised to improve fuel efficiency and keep harmful emissions to a minimum. A range of features have been integrated to ensure smooth, easy and accurate control. The result is a reliable workhorse that enhances your performance and productivity on every job.

Engine

The R18-9AK is equipped with a 3-cylinder, 4-stroke diesel engine built and tested to deliver reliable power along with high fuel efficiency and low emissions. The most compact multi-cylinder, liquid-cooled industrial diesel engine on the market, it is also one of the most hard-working. It runs cleanly, complying with EU Stage V emissions regulations without requiring additional aftertreatment devices. A half-float valve cover and coated pistons reduce noise levels and vibration. To further enhance productivity, a super glow system shortens pre-heating time and ensures quick ignition in cold weather.



Variable undercarriage

The track width can be adjusted between 980 mm and 1,270 mm. The operator can easily adapt the blade size by removing the pin. Specially designed rubber-padded track shoes protect the road surface.

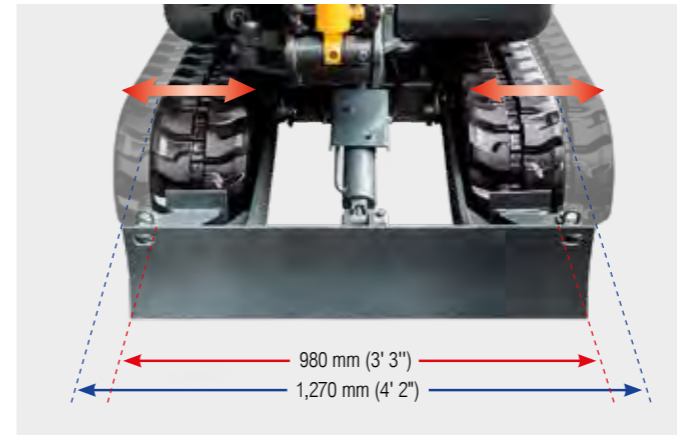

Boom swing

The boom swing function helps you to work more efficiently in congested residential and urban areas. The boom can be offset 60 degrees to the left or right within the operating range.



Hydraulic system

The hydraulic system has optimal matching between the joystick and main control valve to improve fine control and ensure smooth operation. The arm flow summation system saves energy and increases speed. An integrated boom holding system improves safety and avoids boom drift.

Drawbar pull

Travel performance can be improved by increasing drawbar pull on slopes and rough roads.

Increased drawbar pull of travel motor

R16-9		
R18-9AK	26% UP	1.42 ton

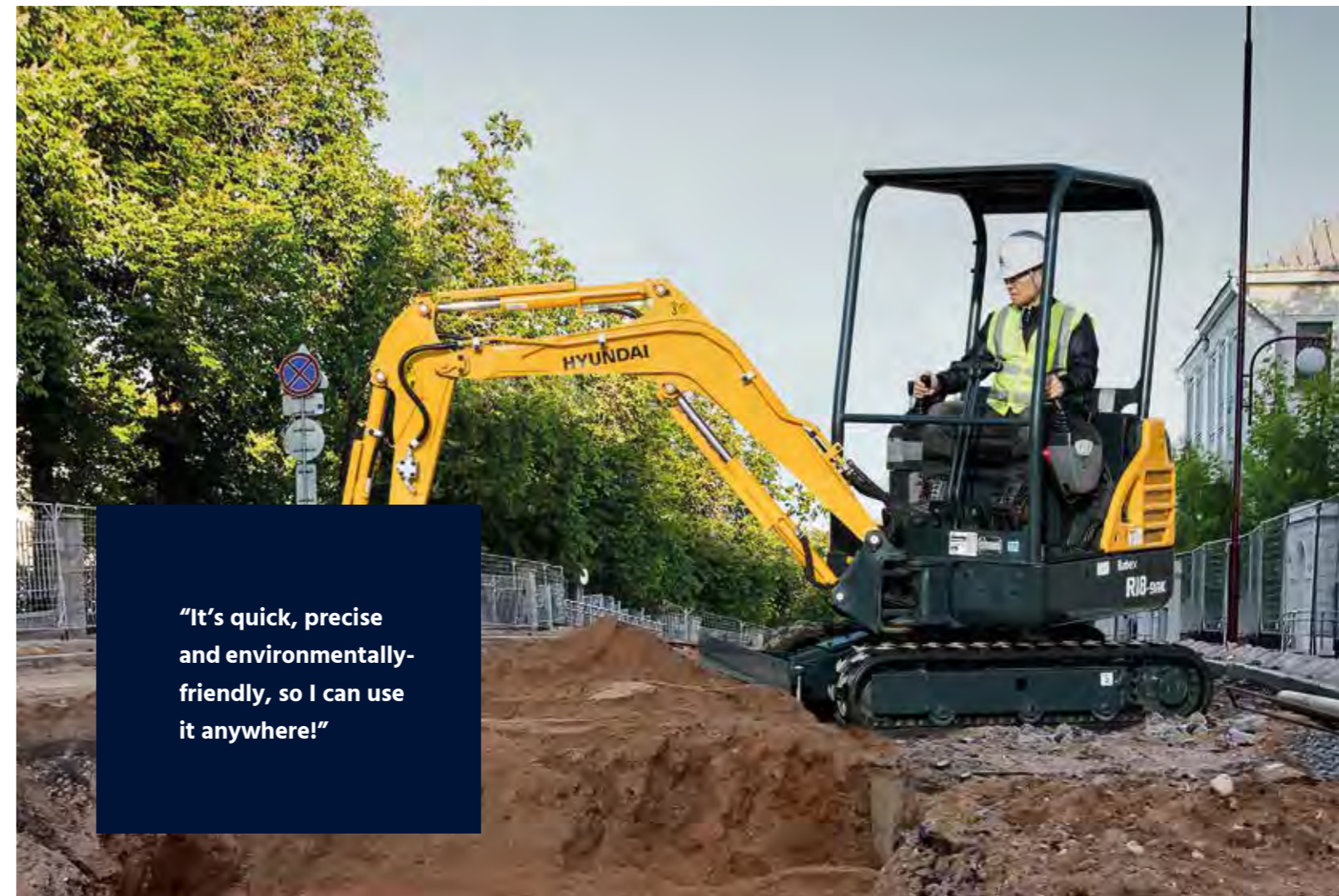

"It's quick, precise and environmentally-friendly, so I can use it anywhere!"

Operator comfort

A CABIN DESIGNED AROUND YOU

The R18-9AK cabin was designed to be a productive, stress-free working environment that fits every operator perfectly. Comfortable and spacious with ample legroom, it features an ergonomic layout allowing easy reach to all controls. Numerous details add to convenience and help you to work longer without fatigue.

“The adjustable seat is very comfortable and all the features and controls are clearly organised.”

Seat and wrist rests

The seat and wrist rests can be easily adjusted to create the perfect fit for every operator.



Pedals and footrest

The footrest, attachment pedal, left and right travel pedals and boom swing pedal are all configured for maximum comfort and convenience.



Cupholders

The right-hand console features two cupholders for storing large and small drinks.



Controls

All control devices are positioned to optimise comfort and operator performance. The right- and left-hand control levers are conveniently placed. The hand levers controlling the dozer blade and track extension are also located within easy reach. Easy-access control switches on the left-hand console improve productivity, while an additional glow control function adds reliability in cold weather conditions. The left-hand console can be tilted to allow easier access to the cabin.



Proportional auxiliary hydraulic system

The proportional control switch allows better speed control and more convenient operation.



Durability & Safety

EXTRA PROTECTION FOR EQUIPMENT AND OPERATORS

To protect your business, you need to know that the investment you make today will sustain your profits over the long term. That's why we prioritised durability throughout the development of the R18-9AK, from design and manufacturing to quality control. Every component has been optimised for endurance and extra protection has been added to protect vital machine parts. Operators are also protected by safety features like all-round visibility, a safety lock system and smooth control that adds to confidence, productivity and peace of mind.



"It may be compact, but this is a tough machine built for big results!"



Safety lock system

The safety lock system prevents the operator from leaving the cabin while the R18-9AK is running. When the safety lever and left-hand console are positioned upright, the hydraulic functions are disengaged.



OLED display and ESL (Engine Start Limit) function

The operator display features simple button functions and easy-to-read indicators, as well as advice on machine status and alerts. The ESL anti-theft system prevents unauthorised ignition.

Durable components

All components are selected for extended service intervals, low operating costs and minimal machine downtime. This includes bushings with prolonged lube intervals (250 hrs), wear-resistant, noise-reducing polymer shims and long-life hydraulic filters (1000 hrs) and hydraulic oil (5000 hrs). Efficient cooling systems and integrated preheating systems further enhance performance and durability.



Cylinder covers

The standard boom cylinder cover and dozer cylinder cover provide additional protection.



Reinforced structure

The structure has been optimised by using stronger, slimmer tubing to improve both safety and visibility. Low-stress, high-strength steel is integrally welded to form a stronger, more durable upper and lower frame. FEM (Finite Elements Method) analysis and long-term durability tests have been used to ensure structural integrity.

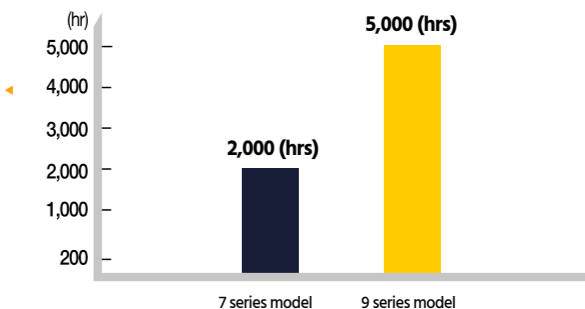

Serviceability

EASY SERVICING FOR TROUBLE-FREE OWNERSHIP

The peace of mind that comes with quick, low-effort servicing is also part of the Hyundai Effect. The R18-9AK is designed for fast, easy maintenance and repairs with convenient access to important servicing points. The engine hood opens wide to provide easy access for cleaning and routine tasks. All components and materials have been optimised to ensure a long, trouble-free life.



“I work to a tight schedule so it’s essential that my machinery runs smoothly and is easy to maintain.”



Flat glass
The cabin windows and panels are designed with flat glass to allow easy replacement in the event of damage.



Air filter
The R18-9AK is fitted with a durable plastic air filter designed for easy maintenance.



Centralised grease points
Grease fittings are centralised in one lubrication bank for quick, easy servicing.

Parts & Warranties

HYUNDAI GENUINE PARTS AND WARRANTIES: THE BEST WAY TO PROTECT YOUR INVESTMENT

Hyundai Genuine parts, accessories and warranty programmes are specially designed to keep your machine covered. They increase uptime and maintain the performance, comfort, and convenience that are built into your equipment.



A network you can rely on

Hyundai Construction Equipment Europe prioritises quick, reliable intervention to keep your equipment running reliably. In the 13,000 m² warehouse, Hyundai covers over 96% of all Genuine Parts. With one of Europe's most advanced automated warehousing systems, we are able to maintain availability and efficient delivery of all our Genuine Parts. Moreover, we guarantee a 24-hour delivery service across our European dealer network.



Fuel filters

Hyundai fuel filters provide the right degree of filtration to keep your engine clean. They are designed to meet and exceed the engine manufacturer's prerequisites for water separation and dirt filtration, prolonging the life of your engine.



Hyundai Genuine parts

Hyundai Genuine parts have the same design as those installed when your machine left the factory. They are subjected to rigorous quality inspections and tests to make sure they meet Hyundai's strict requirements for quality and durability. As well as minimising downtime, this helps to ensure peak performance on every task.



Undercarriage parts

Hyundai track components deliver exceptional ride performance. The materials used comply with stringent quality control measures to ensure highest reliability.



Hyundai warranties

Our warranties are also designed to give you the cover you need to build your business with confidence and peace of mind.

Standard warranties

We offer standard warranty coverage for all compact excavators. Next to this standard coverage, optional and extended warranty periods are available, so you can benefit from full warranty coverage for longer, and even over the full lifetime of the machines. Please discuss the optimal solution for your needs with your local Hyundai dealer.

Extended warranties

Our extended warranties help you maintain full control over your operating costs. If you combine an extended warranty programme with a tailored maintenance contract, you can completely avoid unexpected costs.

Walk-around

R18-9AK

Productivity & Efficiency

- Powerful Stage V-compliant engine **NEW**
- Variable undercarriage
- Extendable dozer blade
- Auxiliary hydraulic circuit as standard
- Fast operation with precise control
- Auto shift-down function **NEW**
- Easy to transport



Durability & Safety

- Robust design
- TOPS/FOPS cabin
- Protective covers on all cylinders
- Safety lock ignition system
- OLED display with ESL anti-theft system
- Long-life hydraulic oil, shims and bushings

Serviceability

- Easy access to service points
- Wide opening covers and hoods
- Centralised grease points
- Flat glass for easy replacement

Operator comfort

- Easy access to cabin
- Adjustable seat
- Ample leg room
- Ergonomic joysticks
- Simple controls
- Excellent all-round visibility

READY TO CHANGE YOUR WORLD

Hyundai's A-Series compact excavators are designed to create better conditions for operators and deliver the ultimate ownership experience. Every detail is carefully fine-tuned to match your needs in the field, including better safety and comfort, higher productivity, maximum uptime and easy servicing. It's all part of the Hyundai Effect.

Explore the range at hyundai-ce.eu



SPECIFICATIONS

ENGINE			
Maker / Model	KUBOTA D902		
Type	4-cycle vertical overhead valve, diesel fuel		
Rated flywheel horse power	SAE	J1995 (gross)	16.2 HP (12.1 kW) at 2,400 rpm
		J1349 (net)	16.0 HP (11.9 kW) at 2,400 rpm
	DIN	6271/1 (gross)	16.5 PS (12.1 kW) at 2,400 rpm
		6271/1 (net)	16.2 PS (11.9 kW) at 2,400 rpm
Max. torque	5.57 kgf/m (40.3 lbf/ft) at 1,800 rpm		
Bore X stroke	72.0 x 73.6 (2.83" x 2.90")		
Piston displacement	898 cc (54.80 cu.in.)		
Batteries	12 V, 80 AH		
Starting motor	12 V-1.2 kW		
Alternator	24 V, 40 A		

HYDRAULIC SYSTEM	
MAIN PUMP	
Type	Variable displacement piston pumps
Rated flow	2 x 18 + 10.8 l/min (2 x 4.8 + 2.9 US gpm/2 x 4.0 + 2.4 UK gpm)
Sub-pump for pilot circuit	Gear pump

HYDRAULIC MOTORS	
Travel	Two speed axial piston motor with counter balance valve
Swing	Axial piston motor with automatic brake

RELIEF VALVE SETTING	
Implement circuits	210 kgf/cm ² (2,990 psi)
Travel circuits	210 kgf/cm ² (2,990 psi)
Swing circuit	200 kgf/cm ² (2840psi)
Pilot circuit	35 kgf/cm ² (498 psi)
Service valve	Installed

HYDRAULIC CYLINDER	
NO. OF CYLINDER - BORE X STROKE	
Boom	60 x 465 mm (2.4" x 18.3")
Arm	60 x 400 mm (2.4" x 15.7")
Bucket	55 x 345 mm (2.2" x 13.6")
Boom swing	55 x 355 mm (2.2" x 14.0")
Dozer blade	65 x 93 mm (2.6" x 3.7")
Extension	50 x 270 mm (2.0" x 10.6")
Shoe width	Rubber shoe 230 mm (9")
Operating weight (canopy)	1,855 kg (4,089 lb)
Ground pressure (canopy)	0.30 kg/cm ² (4.24 psi)
Operating weight (cabin)	1,995 kg (4,398 lb)
Ground pressure (cabin)	0.32 kg/cm ² (4.56 psi)

* Hyundai Bio Hydraulic Oil (HBHO) available

NOISE LEVEL	
NOISE LEVELS (DYNAMIC VALUE)	
LwA	93 dB
LpA	76 dB

COOLANT & LUBRICANT CAPACITY			
Refilling	litre	US gal	UK gal
Fuel tank	21	5.5	4.6
Engine coolant	4.0	1.0	0.9
Engine oil	3.7	1.0	0.8
Hydraulic tank	20	5.3	4.4

TRAVEL LEVERS	
Travelling and steering : Two levers with pedals.	

CONTROL LEVERS	
TYPE	
Pilot control	Two joysticks with one safety lever (LH); Swing and arm (RH); Boom and bucket with horn (ISO)
Engine throttle	Mechanical, cable type

SWING SYSTEM	
Swing motor	Axial piston motor
Swing reduction	Planetary gear reduction
Swing circuit lubrication	Lubricated with drain oil
Swing speed	9.1 rpm
Swing Brake	wet disc

DRIVES & BRAKES	
Max. travel speed (high) / (low)	3.9 km / 2.0 km (2.4 mph) / (1.2 mph)
Maximum traction force	1.42 ton
Maximum gradeability	30°
Parking brake (Option)	wet disc

DIGGING FORCE (ISO)		
	0.96 m Arm	1.12 m Arm
Bucket digging force	1,540 kgf	1,540 kgf
	15.1 kN	15.1 kN
	3,400 lbf	3,400 lbf
Arm crowd force	960 kgf	870 kgf
	9.4 kN	8.5 kN
	2,120 lbf	1,920 lbf

OPERATING WEIGHT	
Operating weight, including 1,800 mm (5' 11") boom, 960 mm (3' 2") arm, SAE heaped 0.04 m ³ (0.05 yd ³) excavator bucket, lubricant, coolant, full fuel tank, hydraulic tank, standard equipment, and operator, 75 kg (165 lb)	
Shoe width	Rubber shoe 230 mm (9")
Operating weight (canopy)	1,855 kg (4,089 lb)
Ground pressure (canopy)	0.30 kg/cm ² (4.24 psi)
Operating weight (cabin)	1,995 kg (4,398 lb)
Ground pressure (cabin)	0.32 kg/cm ² (4.56 psi)

UNDERCARRIAGE	
The centre frame is integrally welded with reinforced box-section track frames. The undercarriage includes lubricated rollers, track adjusters with shock-absorbent springs and sprockets, and rubber shoes.	
Track frame	Variable undercarriage
No. of track rollers on each side	3 EA

DIMENSIONS & WORKING RANGE

R18-9AK DIMENSIONS

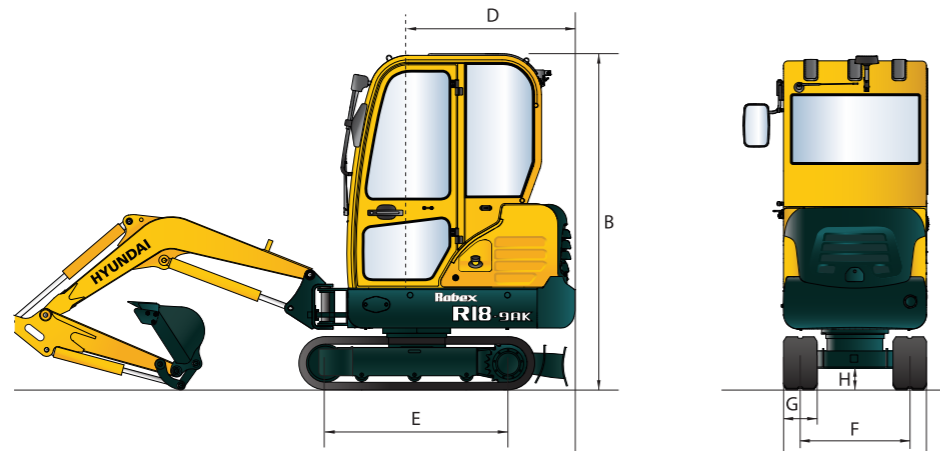

Unit: mm (ft.in.)

A	Overall length	3,840 (12' 7")
B	Overall height	2,300 (7' 7")
C	Overall width	980 ~ 1,270 (3' 3" ~ 4' 2")
D	Tail swing radius	1,065 (3' 6")

E	Tumbler distance	1,230 (4' 0")
F	Track gauge	750 ~ 1,020 (2' 6" ~ 3' 4")
G	Track shoe width	230 (0' 9")
H	Ground clearance	150 (0' 6")

R18-9AK WORKING RANGE

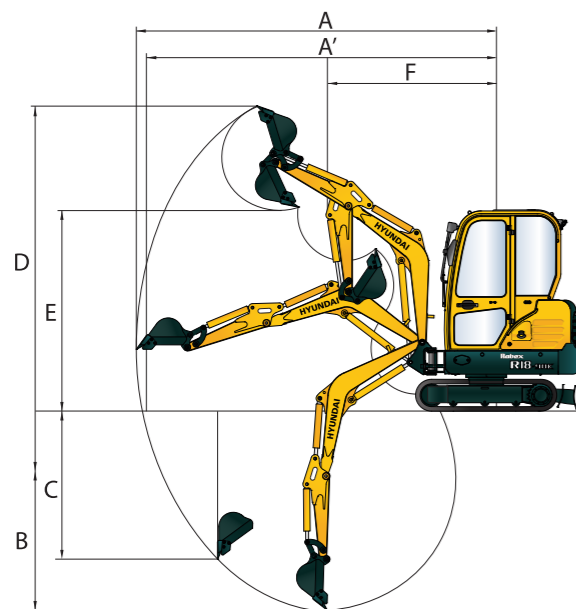

Unit: mm (ft.in.)

	Boom length	1,800 (5' 11")	
	Arm length	960 (3' 2")	1,120 (3' 8")
A	Max. digging reach	3,960 (12' 12")	4,110 (13' 6")
A'	Max. digging reach on ground	3,870 (12' 8")	4,020 (13' 2")
B	Max. digging depth	2,245 (7' 4")	2,405 (7' 11")
C	Max. vertical wall digging depth	1,775 (5' 10")	1,930 (6' 4")
D	Max. digging height	3,675 (12' 1")	3,785 (12' 5")
E	Max. dumping height	2,575 (8' 5")	2,680 (8' 10")
F	Min. swing radius	1,660 (5' 5")	1,695 (5' 7")

LIFTING CAPACITY

Rating over-front Rating over-side or 360 degrees

R18-9AK

Boom : 1.80 m (5' 11") / Arm : 0.96 m (3' 2") / without Bucket / Dozer blade down / 230 mm (9") rubber tracks (extended) / Canopy

Load point height m (ft)	Lift-point radius						At max. Reach		
	2.0 m (6.6 ft)		2.5 m (8.2 ft)		3.0 m (9.8 ft)		Capacity		Reach
									m (ft)
3.0 m 9.8 ft							*400	*400	2.2 (7.2)
2.5 m 8.2 ft			*370	*370			*340	*320	2.76 (9.1)
2.0 m 6.6 ft			*820	*820			*750	710	3.1 (10.2)
1.5 m 4.9 ft	*530	520	*390	380	*390	280	*310	270	3.1 (10.2)
1.0 m 3.3 ft	*1,170	1,150	*860	840	*860	620	*680	600	3.3 (10.8)
0.5 m 1.6 ft	*730	490	*530	360	*450	270	*320	230	3.39 (11.1)
0.0 m 0.0 ft	*1,610	1,080	*1,170	790	*990	600	*710	510	3.39 (11.1)
-0.5 m -1.6 ft	*870	470	*610	350	*480	270	*340	220	3.39 (11.1)
-1.0 m -3.3 ft	*1,920	1,040	*1,340	770	*1,060	600	*750	490	3.39 (11.1)
-1.5 m -4.9 ft	*910	470	*650	340	*500	260	*390	230	3.29 (10.8)
	*2,010	1,040	*1,430	750	*1,100	570	*860	510	3.08 (10.1)
	*880	470	*630	340	*480	260	*450	250	2.74 (9.0)
	*1,940	1,040	*1,390	750	*1,060	570	*990	550	2.74 (9.0)
	*770	470	*550	340			*460	300	2.15 (7.1)
	*1,700	1,040	*1,210	750			*1,010	660	2.15 (7.1)
	*520	480					*440	430	
	*1,150	1,060					*970	950	

Boom : 1.80 m (5' 11") / Arm : 0.96 m (3' 2") / without Bucket / Dozer blade up / 230 mm (9") rubber tracks (extended) / Canopy

Load point height m (ft)	Lift-point radius						At max. Reach		
	2.0 m (6.6 ft)		2.5 m (8.2 ft)		3.0 m (9.8 ft)		Capacity		Reach
									m (ft)
3.0 m 9.8 ft							*400	*400	2.2 (7.2)
2.5 m 8.2 ft			*370	360			320	300	2.76 (9.1)
2.0 m 6.6 ft			*820	790			710	660	3.1 (10.2)
1.5 m 4.9 ft			380	360	280	270	270	250	3.1 (10.2)
1.0 m 3.3 ft	530	490	840	790	620	600	600	550	3.3 (10.8)
0.5 m 1.6 ft	1,170	1,080	370	350	280	260	240	230	3.3 (10.8)
0.0 m 0.0 ft	1,170	1,010	820	770	620	570	530	510	3.39 (11.1)
-0.5 m -1.6 ft	500	460	360	340	270	260	230	210	3.39 (11.1)
-1.0 m -3.3 ft	1,100	1,010	790	750	600	570	510	460	3.39 (11.1)
-1.5 m -4.9 ft	480	450	350	330	270	250	220	210	3.39 (11.1)
	1,060	990	770	730	600	550	490	460	3.29 (10.8)
	470	440	340	320	260	250	230	220	3.08 (10.1)
	1,040	970	750	710	570	550	510	490	3.08 (10.1)
	480	440	340	320			300	280	2.74 (9.0)
	1,060	970	750	710			660	620	2.74 (9.0)
	490	450					440	410	2.15 (7.1)
	1,080	990					970	900	2.15 (7.1)

- Lifting capacity is based on ISO 10567.
- Lifting capacity of the Robex Series does not exceed 75% of the tipping load with the machine on firm, level ground or 87% of full hydraulic capacity.
- The Lift-point is bucket pivot mounting pin on the arm (without bucket mass).
- (*) indicates the load limited by hydraulic capacity.

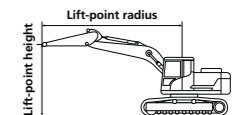

LIFTING CAPACITY

Rating over-front Rating over-side or 360 degrees

R18-9AK

Boom : 1.80 m (5' 11") / Arm : 0.96 m (3' 2") / without Bucket / Dozer blade down / 230 mm (9") rubber tracks (extended) / Cabin

Load point height m (ft)	Lift-point radius						At max. Reach		
	2.0 m (6.6 ft)		2.5 m (8.2 ft)		3.0 m (9.8 ft)		Capacity		Reach
									m (ft)
3.0 m 9.8 ft	kg lb						*400 *880	*400 *880	2.2 (7.2)
2.5 m 8.2 ft	kg lb			*370 *820	*370 *820		*340 *750	*340 *750	2.76 (9.1)
2.0 m 6.6 ft	kg lb			*390 *860	*390 *860	*390 *860	310 680	*310 *680	3.1 (10.2)
1.5 m 4.9 ft	kg lb	*530 *1,170	*530 *1,170	*450 *990	410 900	*410 *900	310 680	*310 *680	3.3 (10.8)
1.0 m 3.3 ft	kg lb	*730 *1,610	550 1,210	*530 *1,170	400 880	*450 *990	300 660	*320 *710	3.39 (11.1)
0.5 m 1.6 ft	kg lb	*870 *1,920	530 1,170	*610 *1,340	390 860	*480 *1,060	300 660	*340 *750	3.39 (11.1)
0.0 m 0.0 ft	kg lb	*910 *2,010	520 1,150	*650 *1,430	380 840	*500 *1,100	300 660	*390 *860	3.29 (10.8)
-0.5 m -1.6 ft	kg lb	*880 *1,940	520 1,150	*630 *1,390	380 840	*480 *1,060	290 640	*450 *990	3.08 (10.1)
-1.0 m -3.3 ft	kg lb	*770 *1,700	520 1,150	*550 *1,210	380 840			*460 *1,010	2.74 (9.0)
-1.5 m -4.9 ft	kg lb	*520 *1,150	*520 *1,150					*440 *970	2.15 (7.1)

Boom : 1.80 m (5' 11") / Arm : 0.96 m (3' 2") / without Bucket / Dozer blade up / 230 mm (9") rubber tracks (extended) / Cabin

Load point height m (ft)	Lift-point radius						At max. Reach		
	2.0 m (6.6 ft)		2.5 m (8.2 ft)		3.0 m (9.8 ft)		Capacity		Reach
									m (ft)
3.0 m 9.8 ft	kg lb						*400 *880	*400 *880	2.2 (7.2)
2.5 m 8.2 ft	kg lb			*370 *820	*370 *820		*340 *750	*340 *750	2.76 (9.1)
2.0 m 6.6 ft	kg lb			*390 *860	*390 *860	320 710	300 660	280 620	3.1 (10.2)
1.5 m 4.9 ft	kg lb	*530 *1,170	*530 *1,170	410 900	390 860	310 680	290 640	270 600	3.3 (10.8)
1.0 m 3.3 ft	kg lb	560 1,230	520 1,150	400 880	380 840	310 680	290 640	260 570	3.39 (11.1)
0.5 m 1.6 ft	kg lb	540 1,190	500 1,100	390 860	360 790	300 660	280 620	250 550	3.39 (11.1)
0.0 m 0.0 ft	kg lb	530 1,170	490 1,080	380 840	360 790	300 660	280 620	260 570	3.29 (10.8)
-0.5 m -1.6 ft	kg lb	530 1,170	490 1,080	380 840	360 790	300 660	280 620	290 600	3.08 (10.1)
-1.0 m -3.3 ft	kg lb	540 1,190	490 1,080	390 860	360 790			340 750	2.74 (9.0)
-1.5 m -4.9 ft	kg lb	*520 *1,150	510 1,120					*440 *970	2.15 (7.1)

- Lifting capacity is based on ISO 10567.
- Lifting capacity of the Robex Series does not exceed 75% of the tipping load with the machine on firm, level ground or 87% of full hydraulic capacity.
- The Lift-point is bucket pivot mounting pin on the arm (without bucket mass).
- (*) indicates the load limited by hydraulic capacity.

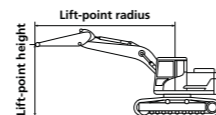

LIFTING CAPACITY

Rating over-front Rating over-side or 360 degrees

R18-9AK

Boom : 1.80 m (5' 11") / Arm : 1.12 m (3' 8") / without Bucket / Dozer blade down / 230 mm (9") rubber tracks (extended) / Canopy

Load point height m (ft)	Lift-point radius								At max. Reach			
	2.0 m (6.6 ft)		2.5 m (8.2 ft)		3.0 m (9.8 ft)		3.5 m (11.5 ft)		Capacity		Reach	
											m (ft)	
2.5 m 8.2 ft	kg lb			*320 *710	*320 *710					*280 *620	*280 *620	2.96 (9.7)
2.0 m 6.6 ft	kg lb			*340 *750	*340 *750	*350 *770	280 620			*260 *570	*240 530	3.27 (10.7)
1.5 m 4.9 ft	kg lb	*460 *1,010	*460 *1,010	*410 *900	370 820	*380 *840	280 620			*260 *570	220 490	3.45 (11.3)
1.0 m 3.3 ft	kg lb	*660 *1,460	500 1,100	*500 *1,100	360 790	*420 *930	270 600	*340 *750	210 460	*270 *600	210 460	3.54 (11.6)
0.5 m 1.6 ft	kg lb	*830 *1,830	470 1,040	*580 *1,280	340 750	*460 *1,010	260 570	*370 *820	210 460	*280 *620	210 460	3.54 (11.6)
0.0 m 0.0 ft	kg lb	*900 *1,980	460 1,010	*630 *1,390	330 730	*490 *1,080	260 570			*320 *710	210 460	3.45 (11.3)
-0.5 m -1.6 ft	kg lb	*890 *1,960	460 1,010	*640 *1,410	330 730	*490 *1,080	260 570			*370 *820	230 510	3.25 (10.7)
-1.0 m -3.3 ft	kg lb	*810 *1,790	460 1,010	*580 *1,280	330 730					*430 *950	270 600	2.93 (9.6)
-1.5 m -4.9 ft	kg lb	*620 *1,370	470 1,040							*430 *950	360 790	2.42 (7.9)

Boom : 1.80 m (5' 11") / Arm : 1.12 m (3' 8") / without Bucket / Dozer blade up / 230 mm (9") rubber tracks (extended) / Canopy

Load point height m (ft)	Lift-point radius								At max. Reach			
	2.0 m (6.6 ft)		2.5 m (8.2 ft)		3.0 m (9.8 ft)		3.5 m (11.5 ft)		Capacity		Reach	
											m (ft)	
2.5 m 8.2 ft	kg lb			*320 *710	*320 *710					*280 *620	270 600	2.96 (9.7)
2.0 m 6.6 ft	kg lb			*340 *750	*340 *750	280 620	270 600			240 530	230 510	3.27 (10.7)
1.5 m 4.9 ft	kg lb	*460 *1,010	*460 *1,010	370 820	350 770	280 620	260 570			220 490	210 460	3.45 (11.3)
1.0 m 3.3 ft	kg lb	500 1,100	470 1,040	360 790	340 750	270 600	260 570	210 460	200 440	210 460	200 440	3.54 (11.6)
0.5 m 1.6 ft	kg lb	480 1,060	440 970	350 770	320 710	270 600	250 550	210 460	200 440	210 460	200 440	3.54 (11.6)
0.0 m 0.0 ft	kg lb	470 1,040	430 950	340 750	320 710	260 570	240 530			210 460	200 440	3.45 (11.3)
-0.5 m -1.6 ft	kg lb	460 1,010	430 950	330 730	310 680	260 570	240 530			230 510	220 490	3.25 (10.7)
-1.0 m -3.3 ft	kg lb	470 1,040	430 950	340 750	310 680					270 600	250 550	2.93 (9.6)
-1.5 m -4.9 ft	kg lb	480 1,060	440 970							360 790	340 750	2.42 (7.9)

- Lifting capacity is based on ISO 10567.
- Lifting capacity of the Robex Series does not exceed 75% of the tipping load with the machine on firm, level ground or 87% of full hydraulic capacity.
- The Lift-point is bucket pivot mounting pin on the arm (without bucket mass).
- (*) indicates the load limited by hydraulic capacity.

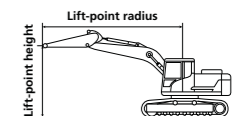

LIFTING CAPACITY

Rating over-front Rating over-side or 360 degrees

R18-9AK

Boom : 1.80 m (5' 11") / Arm : 1.12 m (3' 8") / without Bucket / Dozer blade down / 230 mm (9") rubber tracks (extended) / Cabin

Load point height m (ft)	Lift-point radius								At max. Reach		
	2.0 m (6.6 ft)		2.5 m (8.2 ft)		3.0 m (9.8 ft)		3.5 m (11.5 ft)		Capacity	Reach	
2.5 m 8.2 ft	kg lb		*320 *710	*320 *710					*280 *620	*280 *620	2.96 (9.7)
2.0 m 6.6 ft	kg lb		*340 *750	*340 *750	*350 *770	310 680			*260 *570	*260 *570	3.27 (10.7)
1.5 m 4.9 ft	kg lb	*460 *1,010	*460 *1,010	*410 *900	*410 *900	*380 *840	310 680		*260 *570	250 550	3.45 (11.3)
1.0 m 3.3 ft	kg lb	*660 *1,460	550 1,210	*500 *1,100	400 880	*420 *930	300 660	*340 *750	240 530	240 530	3.54 (11.6)
0.5 m 1.6 ft	kg lb	*830 *1,830	530 1,170	*580 *1,280	380 840	*460 *1,010	300 660	*370 *820	240 530	230 510	3.54 (11.6)
0.0 m 0.0 ft	kg lb	*900 *1,980	520 1,150	*630 *1,390	380 840	*490 *1,080	290 640		*320 *710	240 530	3.45 (11.3)
-0.5 m -1.6 ft	kg lb	*890 *1,960	510 1,120	*640 *1,410	370 820	*490 *1,080	290 640		*370 *820	260 570	3.25 (10.7)
-1.0 m -3.3 ft	kg lb	*810 *1,790	520 1,150	*580 *1,280	370 820				*430 *950	300 660	2.93 (9.6)
-1.5 m -4.9 ft	kg lb	*620 *1,370	530 1,170						*430 *950	400 880	2.42 (7.9)

Boom : 1.80 m (5' 11") / Arm : 1.12 m (3' 8") / without Bucket / Dozer blade up / 230 mm (9") rubber tracks (extended) / Cabin

Load point height m (ft)	Lift-point radius								At max. Reach		
	2.0 m (6.6 ft)		2.5 m (8.2 ft)		3.0 m (9.8 ft)		3.5 m (11.5 ft)		Capacity	Reach	
2.5 m 8.2 ft	kg lb		*320 *710	*320 *710					*280 *620	*280 *620	2.96 (9.7)
2.0 m 6.6 ft	kg lb		*340 *750	*340 *750	320 710	300 660			*260 *570	260 570	3.27 (10.7)
1.5 m 4.9 ft	kg lb	*460 *1,010	*460 *1,010	*410 *900	390 860	310 680	290 640		250 550	230 510	3.45 (11.3)
1.0 m 3.3 ft	kg lb	560 1,230	520 1,150	400 880	370 820	310 680	290 640	240 530	240 530	220 490	3.54 (11.6)
0.5 m 1.6 ft	kg lb	540 1,190	500 1,100	390 860	360 790	300 660	280 620	240 530	240 530	220 490	3.54 (11.6)
0.0 m 0.0 ft	kg lb	530 1,170	480 1,060	380 840	350 770	290 640	280 620		240 530	230 510	3.45 (11.3)
-0.5 m -1.6 ft	kg lb	520 1,150	480 1,060	380 840	350 770	290 640	270 600		260 570	250 550	3.25 (10.7)
-1.0 m -3.3 ft	kg lb	530 1,170	480 1,060	380 840	350 770				300 660	280 620	2.93 (9.6)
-1.5 m -4.9 ft	kg lb	540 1,190	490 1,080						410 900	380 840	2.42 (7.9)

- Lifting capacity is based on ISO 10567.
- Lifting capacity of the Robex Series does not exceed 75% of the tipping load with the machine on firm, level ground or 87% of full hydraulic capacity.
- The Lift-point is bucket pivot mounting pin on the arm (without bucket mass).
- (*) indicates the load limited by hydraulic capacity.

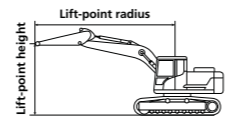

STANDARD/OPTIONAL EQUIPMENT

STANDARD EQUIPMENT
ISO STANDARD CANOPY
Canopy FOPS (ISO 10262)
Canopy TOPS (ISO 12117)
GAUGES
Fuel level gauge
Engine coolant
Temperature gauge
WARNING
Quick coupler
Engine oil pressure
Engine coolant temperature
Preheat
Low battery
Air cleaner clogging
Low fuel level
TRAVEL MOTOR WITH PARKING BRAKE
ONE KEY
ADJUSTABLE SUSPENSION SEAT WITH SEAT BELT
CONSOLE BOX TILTING SYSTEM (LH.)
TWO FRONT WORKING LIGHTS
ELECTRIC HORN
BATTERY (1 X 12 V X 80 AH)
BATTERY MASTER SWITCH
AUTOMATIC SWING BRAKE
REMOVABLE RESERVOIR TANK
WATER SEPARATOR, FUEL LINE
MONO BOOM (1.80 M, 5' 11")
ARM (0.96 M, 3' 2")
RUBBER CRAWLER (230 MM, 9")
SINGLE ACTING PIPING (BREAKER, ETC)
DOUBLE ACTING PIPING (CLAMSHELL, ETC)
AUTO SHIFT TRAVELING SYSTEM
EMERGENCY STOP SWITCH
TOOL BOX
GLOW CONTROL

OPTIONAL EQUIPMENT
TOOL KIT
PATTERN CHANGE VALVE
CABIN FOPS (ISO 10262) / TOPS (ISO 12117)
PROPORTIONAL AUXILIARY HYDRAULIC LINE
PROPORTIONAL ROTATION PIPING
HEATING FOR CABIN
LONG ARM (1.12 M, 3'8")
CABIN LIGHT
BEACON LAMP
MP3 RADIO
QUICK COUPLER PIPING
CENTRAL GREASING SYSTEM
BOOM/ARM SAFETY VALVES (FOR LIFTING WORK OVER 1,000 KG)

- * Standard and optional equipment may vary. Contact your Hyundai dealer for more information. The machine may vary according to International standards.
- * The photos may include attachments and optional equipment that are not available in your area.
- * Materials and specifications are subject to change without advance notice.
- * All imperial measurements rounded off to the nearest pound or inch.



Specifications and design are subject to change without notice. Pictures of Hyundai Construction Equipment Europe products may show other than standard equipment.

Hyundai Construction Equipment Europe nv.
Hyundailaan 4, 3980 Tessenderlo, Belgium.
Tel: (+32) 14-56-2200 Fax: (+32) 14-59-3405

EN - 2020.10 Rev.0

Ready to experience the Hyundai Effect?

Contact your Hyundai dealer.
hyundai-ce.eu/en/dealer-locator