

Engine output: **18.4 PS / 13.5 kW**

Machine weight (Cabin/Canopy): **2,305 / 2,105 kg**

**For Earth, For Life**  
**Kubota**

**KUBOTA ZERO-TAIL SWING MINI-EXCAVATOR**

**U20-3*α***



# Intelligent design, sophisticated performance, and new levels of security, and comfort. This mini-excavators is ready for today's tough jobs.

This is mini for modern jobs. Those tough jobs in tight corners that demand precision control, state-of-the-art performance, and maximum safety and security. And this mini is ready to work, offering a wealth of advanced features, including a sophisticated digital panel information system, and the industry's first anti-theft system to be offered as standard equipment. Add high reliability, low operating costs, and superior efficiency, and you've got the ideal mini for a wide range of modern jobs.

## U20-3α



### ANTI-THEFT SYSTEM

The Ultimate in security that's as easy as turning a key. It's the industry's first standard-equipment anti-theft system, and another original only from Kubota.

#### THE IMMOBILIZING SYSTEM

The industry's first standard-equipment anti-theft system makes security as easy as turning a key – the correct key – because the engine only starts when you insert the correct IC-equipped operation key.

#### SECURITY

Only an appropriately programmed operation key will start the engine. Inserting other keys and turning them more than six times activates an alarm, which will stop only when the correct key is inserted and the ignition switched to RUN.

#### EASY PROGRAMMING

One programming key (red) and two operation keys (black) are provided. To program additional operation keys, simply insert the red key and follow the instructions on the digital panel. A maximum of four black keys can be programmed per mini-excavator.

#### EASY OPERATION

No special procedures, no PIN numbers to remember. Simply insert the key to start the engine or gain access to the cabin door, engine bonnet, or fuel tank.

#### Programmed key



#### Un-programmed key



### DIGITAL PANEL

Following the excellence of Kubota's Control System, the digital panel puts convenience at the operator's fingertips. The user-friendly digital panel is positioned to the right side of the operator and features one-touch button operation to view the time, hour meter and tachometer. Warning lamps with code numbers on the display will alert you in case of emergencies such as overheating, hydraulic problems or low battery. Programming of the anti-theft keys can also be easily performed with the digital panel. With easier access, simpler settings, easy-to-read indicators and alerts, you'll always be aware of the excavator's functioning status.

1. Fuel Level Gauge
2. Water Temperature Gauge
3. Warning Lamps (Overheating, Hydraulic, Battery)
4. LCD Display (Time, Hour, rpm)

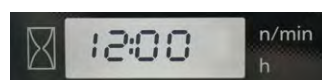

Time

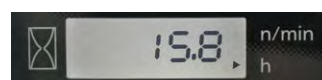

Hour meter

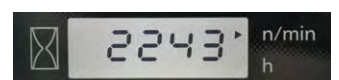

Tachometer



## ZERO-TAIL SWING

With zero-tail swing, even the tightest spaces become efficient work places. The tail always stays within the width of the tracks, letting you turn the cab throughout its 360-degree turning radius with complete confidence and safety and fewer accidents with things behind you. Zero-tail swing also means excellent balance and stability and faster operation, making the U20-3 $\alpha$  ideal for work in congested urban areas and inside buildings.



### Undercarriage

The U20-3 $\alpha$ 's hydraulic track gauge adjusts to between 1300 mm and 1500 mm. A single lever lets you reduce the track gauge to navigate narrow spaces or increase it to improve stability while operating with hydraulic breakers, etc.



Instantly and simply adjust the blade size by removing the pin and folding or unfolding the blade.

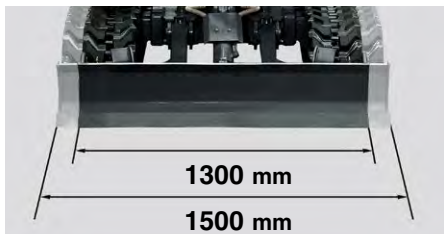

Increase the track gauge for greater stability, or reduce it to navigate narrow spaces.

# Dependable Performance from a Wealth of Advanced Features. And Safety You Can Rely On.

## Kubota engine

Kubota's unique, new E-TVCS (Three Vortex Combustion System) enables high-energy output, low vibration, and low fuel consumption, while minimising exhaust emissions.



## Simultaneous operation of four functions

When the simultaneous operation of the boom, arm, bucket, and swivel are required, two variable pumps will distribute an accurate amount of oil flow to each actuator according to the lever stroke pressure. This process is achieved without the loss of speed or power, and enables continuous high performance digging and dozing.

## Powerful digging force

Even with the optional long arm, the U20-3 $\alpha$  is exceptionally stable and well balanced, giving it a powerful digging force that makes short work of even the toughest digging jobs.



## Long arm

The optional long arm gives this mini-excavator a longer reach, letting you get more work done at each location.



## Travelling System

Rough terrain is not a problem for this rugged traveler, thanks to a powerful traveling force. The traveling system includes traveling lock levers that activate whenever the pilot control safety lever is not engaged, preventing the machine from moving unexpectedly.

### Swivel negative brake

Kubota's swivel negative brake eliminates the need for a swivel transport locking pin. It automatically locks the cabin in its current position whenever the engine is stopped or the pilot control safety level is raised.

### ROPS/FOPS Cabin/canopy (Level 1)

Maximum operator safety is ensured by the integrated Roll-Over Protective Structure (ROPS) and Falling Object Protective Structure (FOPS). Both cabin and canopy versions are available. The cabin version features a stylish layout that provides a high level of operator comfort.



### Ergonomic design

Smooth operation is the key to reducing operator fatigue. That's why the U20-3A features ergonomically designed levers, wrist rests, and high-back seat that enhance operator comfort as well as ensure smooth, precise control.



### Straight travel

For safer loading/off-loading, the Hydraulic Matching System ensures straight travel even during simultaneous operation.

### 2-Speed Travel Switch on Dozer Lever

Conveniently located on the dozer lever for more efficient dozer operation, the newly designed travel switch lets you quickly and easily change travel speeds. The new location also provides more legroom for greater operator comfort.



# Intelligent Design for Easy Maintenance, Rugged Construction for Durable Performance.

## Easy engine inspection

Major components, such as the engine and air cleaner, are easily accessible for inspection and maintenance through the engine cover. An engine inspection cover behind the seat offers fast access to the engine's injection nozzles. A side cover on the right side of the cab provides quick and simple access to the battery, fuel tank and hydraulic tank.



## Protected bucket cylinder hoses

Cylinder hoses are routed within the arm for greater safety. This design vastly improves operator visibility, increases service life, and lowers repair costs.



## Boom cylinder protector

The thick, steel-plated, V-shaped, boom-cylinder protector safeguards against accidental damage from attachments or other objects.



## Two-piece hose design

The innovative, two-piece, hydraulic hose design for the dozer reduces hose replacement time by 60% when compared to a one-piece hose design. What's more, this design virtually eliminates heavy labour from the actual hose replacement process.



## Control valve inspection

Located beneath the cabin floor, the control valve can be accessed by simply removing the steps by hand. When an involved repair is required, the steps and cover below the seat can all be removed by using standard tools.

# Standard Equipment

## Engine/Fuel System

- Kubota original engine
- Double-element air cleaner
- Electric fuel pump

## Undercarriage

- 250mm rubber track
- 1 x upper-track roller
- 3 x double-flange track roller
- 2-speed travel switch on dozer lever
- Variable track system

## Hydraulic System

- Pressure accumulator
- Hydraulic pressure checking ports
- Straight travel circuit
- Third-line hydraulic return

## Safety System

- Engine Start Safety System on the left console
- Travel Lock System on the left console
- Swivel Lock System

- Boom check valve
- Anti-theft system

## Working Equipment

- 1190mm arm
- Auxiliary hydraulic circuit piping to the arm's end
- 2 working lights on the cabin and 1 light on the boom

## Cabin

- ROPS (Roll-Over Protective Structure, ISO 3471)
- FOPS (Falling Objects Protective Structure) Level 1
- Weight adjustable semi-suspension seat
- Seatbelt
- Hydraulic pilot control levers with wrist rests
- Cabin heater for defrosting & demisting
- Emergency exit hammer
- Location for 2 speakers and radio antenna

## Canopy

- ROPS (Roll-Over Protective Structure, ISO 3471)
- FOPS (Falling Objects Protective Structure) Level 1
- Weight-adjustable, semi-suspension seat
- Seatbelt
- Hydraulic pilot control levers with wrist rests

## Optional Equipment

### Undercarriage

- 250mm steel track (+ 60kg)



## Kubota Genuine and Approved Parts

for maximum performance, durability and safety



# SPECIFICATIONS

\*Rubber shoe type

Model		U20-3a		
Type	Cabin	Canopy		
Operating weight*1 (variable track)	kg	2380	2180	
Engine	Model	D1105-E4-BH		
	Type	Water-cooled, diesel engine ETVCS		
	Output ISO90249	PS / rpm	18.4 / 2200	
		kW / rpm	13.5 / 2200	
	Number of cylinders	3		
	Bore x Stroke	mm	72 x 78.4	
Displacement	cc	1123		
Overall length	mm	3850		
Overall height	mm	2360	2370	
Swivelling speed	rpm	9.6		
Rubber shoe width	mm	250		
Dozer size (width x height)	mm	1300 / 1500 x 290		
Hydraulic pumps	P1,P2	Variable displacement pump		
	Flow rate	ℓ/min	23 + 23	
	Hydraulic pressure	MPa(kgf/cm <sup>2</sup> )	21.6 (220.0)	
	P3	Gear type		
	Flow rate	ℓ/min	12.8	
Max. digging force	Arm	kN (kgf)	13.2 (1350)	
	Bucket	kN (kgf)	18.4 (1880)	
Boom swing angle (left/right)	deg	75 / 55		
Auxiliaire circuit	Flow rate	ℓ/min	35.8	
	Hydraulic pressure	MPa(kgf/cm <sup>2</sup> )	21.6 (210.0)	
Hydraulic reservoir	ℓ	22		
Fuel tank capacity	ℓ	28		
Max. travelling speed (low / high)	km/h	2.2 / 4.2		
Ground contact pressure	kPa(kgf/cm <sup>2</sup> )	26.6 (0.27)	25.1 (0.26)	
Ground clearance	mm	160		
Noise level	LpA / LwA (2000/14/EC)	dB (A)	79.6 / 93      78 / 93	
Vibration*2	Hand arm system (ISO 5349-2:2001)	Digging / Levelling	m/s2 RMS <2.5 / <2.5	
		Driving / Idling	m/s2 RMS <2.5 / <2.5	
	Whole body (ISO 2631-1:1997)	Digging / Levelling	m/s2 RMS <0.5 / <0.5	
		Driving / Idling	m/s2 RMS <0.5 / <0.5	

\*1 With 47.5 kg Kubota original bucket, 75 kg operator, full tanks.

\*2 These values are measured under specific conditions at maximum engine speed and can deviate, depending on the operating status.

# LIFTING CAPACITY

**With standard track type, 940 mm arm, cabin** kN (ton)

Lift Point Height	Lifting point radius (2m)			Lifting point radius (Max)		
	Over-front		Over-side	Over-front		Over-side
	Blade Down	Blade UP		Blade Down	Blade UP	
1.5m	6.9 (0.71)	6.4 (0.65)	5.4 (0.55)	-	-	-
1.0m	9.1 (0.93)	6.1 (0.62)	5.1 (0.52)	4.4 (0.44)	2.6 (0.26)	2.2 (0.23)
0m	-	5.8 (0.59)	4.9 (0.50)	-	-	-
-1.0m	7.4 (0.76)	5.9 (0.60)	4.9 (0.50)	-	-	-

**With variable track type, 1190 mm arm, cabin** kN (ton)

Lift Point Height	Lifting point radius (2.5m)			Lifting point radius (Max)		
	Over-front		Over-side	Over-front		Over-side
	Blade Down	Blade UP		Blade Down	Blade UP	
1.5m	4.7 (0.48)	4.5 (0.46)	4.6 (0.47)	-	-	-
1.0m	5.8 (0.59)	4.3 (0.44)	4.5 (0.45)	3.9 (0.40)	2.5 (0.25)	2.4 (0.25)
0m	7.0 (0.72)	4.1 (0.42)	4.2 (0.43)	-	-	-
-1.0m	6.1 (0.62)	4.1 (0.42)	4.2 (0.43)	-	-	-

Please note:

\* The lifting capacities are based on ISO 10567 and do not exceed 75% of the static tilt load of the machine or 87% of the hydraulic lifting capacity of the machine.

\* The excavator bucket, hook, sling and other lifting accessories are not included on this table.

# WORKING RANGE

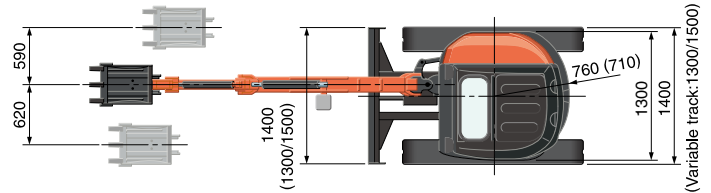

**With standard track type, 940 mm arm**

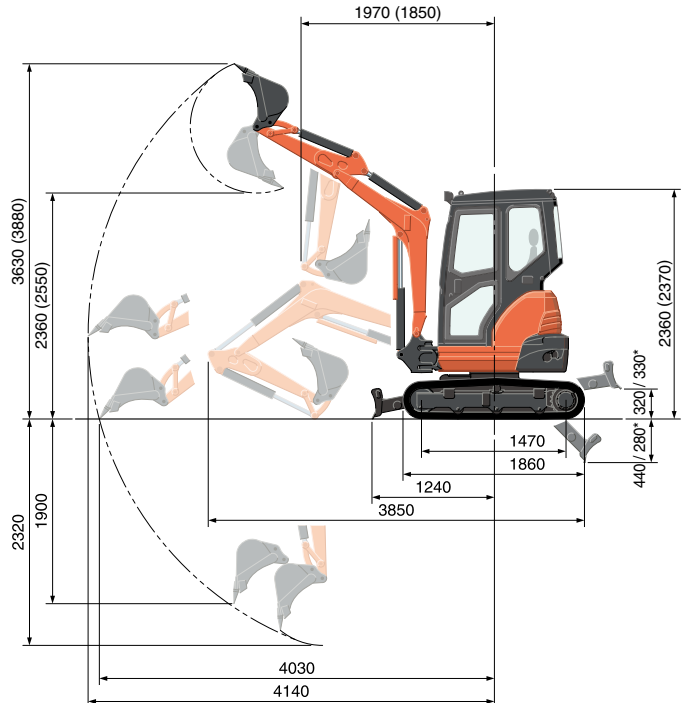

**With standard track type, 1190 mm arm**

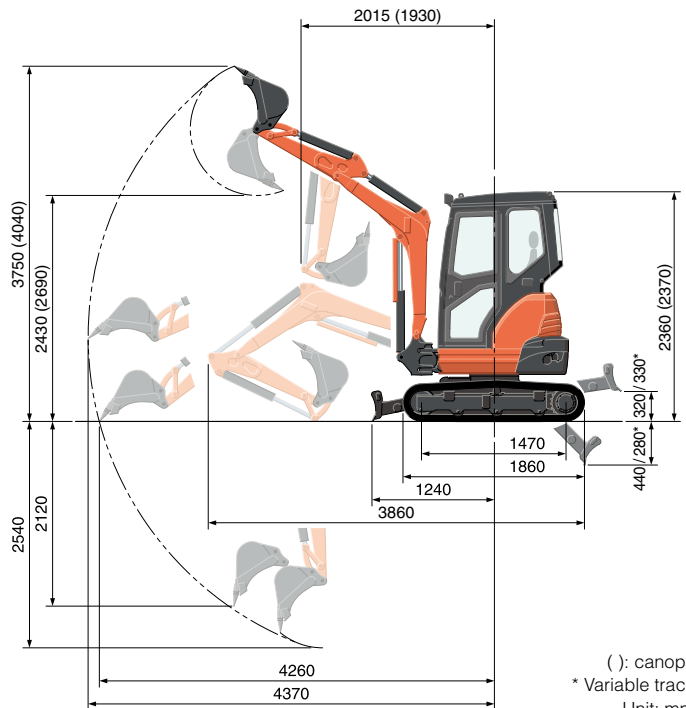

( ): canopy  
\* Variable track  
Unit: mm

\* Working ranges are with Kubota original bucket, without quick coupler.

\* Specifications are subject to change without notice for purpose of improvement.

## KUBOTA EUROPE S.A.S.

19 rue Jules Verceyruysse  
Zone Industrielle - CS 50088  
95101 Argenteuil Cedex France  
Téléphone : (33) 01 34 26 34 34  
Télécopieur : (33) 01 34 26 34 99

## KUBOTA (U.K.) LTD

Dormer Road, Thame, Oxfordshire,  
OX9 3UN, U.K.  
Phone : 01844-268140  
F a x : 01844-216685

## KUBOTA Baumaschinen GmbH

Steinhauser Straße 100  
D-66482 Zweibrücken Germany  
Telefon : (49) 0 63 32 - 487 - 312  
F a x : (49) 0 63 32 - 487 - 101

